



# FREESTANDING APPLIANCES

2016

**gorenje**  
*Life Simplified*



# QUALITY AND TRADITION

Gorenje has been producing high-quality home appliances for over 60 years. It is committed to the research and development and continuous technological improvement to its production processes. Drawing on Slovenian tradition and European values, Gorenje remains among the leading home appliance manufacturers in Europe. We are proud of every product that leaves our factories as we are aware that it was produced and tested to meet the stringent European environment protection standards.





**COOKERS**

**04**



**RETRO COLLECTION**

**16**



**COOLING**

**28**



**WASHING MACHINES**

**46**



**TUMBLE DRYERS**

**60**



**DISHWASHERS**

**72**





# A COOKING ALL-ROUNDER

## Cookers

The best food is fresh, homemade, and healthy. If you agree, then a Gorenje cooker is your ideal companion. A single appliance combines a highly efficient cooking hob and an oven that offers all the advantages similar to baking in traditional wood-fired ovens. These multi-talented helpers will easily adjust to any kitchen layout. They are the perfect choice for those looking to highlight the pleasant cosiness of their home.



## Gas hobs

Innovatively designed Gorenje gas hob burners optimize the flame to allow faster cooking and ultimate efficiency of the use of gas. Air and gas mixture is closer to optimum than in

conventional burners used to date, and the use of gas and control of flame are considerably improved.



### WokBurner Genuine Asian taste, at home

The wok burners reach a high heat wok burner reaches a high heat quicker, making Asian style cuisine and meals in big pots easy.



### Cast iron grids Great looking, stable and durable

The cast iron grids improve the stability and enhance the appearance of the gas cooker. They are made of a material that makes them particularly durable and resistant even to the highest temperatures.



## Induction hobs

Induction hobs heat up twice as fast as Ceramic hobs, which makes them comparatively more economical and safe. An induction hob only heats the bottom of the pan while the remaining hob surface stays cool and always safe to touch.

Temperature is adjusted instantly, limiting the danger of boiling over. With such a hob melted chocolate, sophisticated sauces and other temperature-sensitive masterpieces become just a simple task.



### BoilControl

Boiling over is a forgotten problem

Automatically adjusts the operating power. After initially operating at maximum power, the cooking zone maintains the desired temperature to prevent boiling over or overcooking.

## Fast and Economical

Time required to heat 2 l of water at 15° C to 90° C.

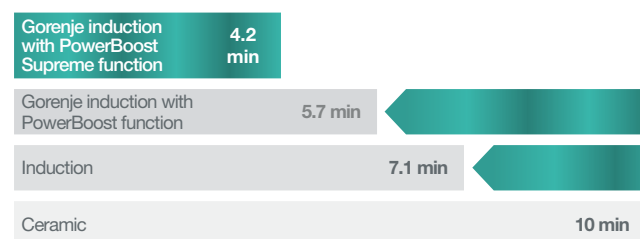



## HomeMade shape

All the qualities of baking  
in wood-burning ovens

The characteristic rounded shape is one of the most beneficial features of Gorenje ovens. Inspired by traditional wood-burning ovens, it enables hot air to move around freely. Since the food is heated evenly and from all sides, it is always perfectly done: crispy on the outside and juicy on the inside.

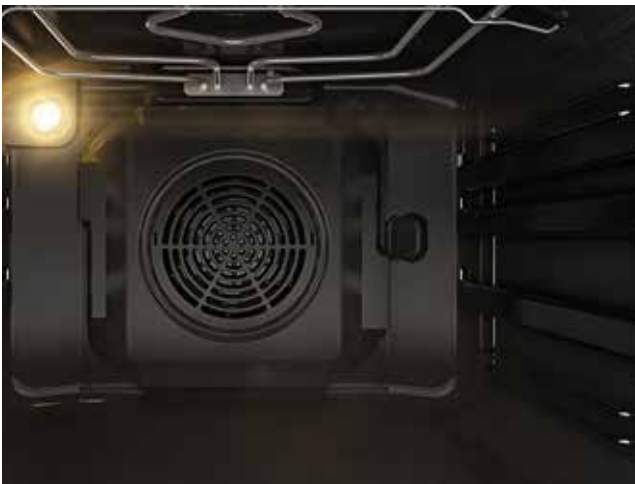

## SilverMatte

Ultra resistant, ultra smooth coating

Enamel quality and type are exceptionally important for the oven and its operation. SilverMatte is a highly resistant and strong material that can stand extreme heats. Free from micro pores, it coats oven surfaces and baking trays, making them resistant to the highest temperatures. The triple coating of the interior supports heat reflection and provides additional insulation. Therefore, the oven interior always stays sterile and safe.



## AquaClean

Simple, casual cleaning

Due to completely new enamel in all new Gorenje ovens, AquaClean function has been significantly improved. AquaClean offers great assistance in cleaning of the oven cavity. All it takes is to pour half a litre of water into a baking tray and turn AquaClean on after each baking. In just 30 minutes, the results are visible on the entire surface and the baking trays. Stains and grease are softened and can be wiped away more easily and the oven stays spotless.





## BigSpace

More space for greater cooking freedom

The new generation of Gorenje ovens has a concealed shape within the upper part. Now the optimised airflow circulates inside the oven, circling completely freely. With their 67-litre useful capacity Gorenje ovens can easily accommodate even a 7 kg turkey.



## OpenView

Excellent view

Advanced models feature double lighting of the large oven cavity. Combined with the glass door, it affords a clear view of the cooking process.



## SuperSize

XXL trays fit in any oven

More spacious ovens allow you to cook bigger meals because of even air circulation at all levels, but also because of the 46cm wide baking trays. Innovative solutions allow a larger interior and the oven width is fully used. There is more space on each baking tray and the superior technology makes sure the food is cooked evenly on all levels.



## PerfectGrill

Crunchy on the outside, soft on the inside

The best baking results are achieved with a combination of larger and smaller heaters, where the latter is positioned inside the larger one. The smart positioning of the heaters allows optimal heat distribution and provides the ultimate baking results every time, so food is crispy on the outside and soft on the inside. A variable heater combination can use either the inner or outer heater, or both at once. In advanced models, the heater is movable for easier cleaning and maintenance.

## ChildLock

ChildLock option is excellent for those who have children at home. Leaving them in a kitchen alone has never been safer, since this option prevents them from resetting any parameters.

## IconTouch

IconTouch allows controlling your oven by touching a screen and by using the ergonomically designed knobs.

## DC+ System

The DynamiCooling system efficiently cools the oven exterior (or housing) to prevent any damage caused by high temperature. In ovens with the DynamiCooling+ system, the heat sensors regulate the cooling of the oven exterior walls until they reach a temperature of 60 °C. This is particularly convenient in ovens with the pyrolytic cleaning function which works with extremely high temperatures.

## Baking on several levels at the same time

The cookers allow baking on three levels simultaneously. Efficient air circulation leads to excellent baking results while saving time and energy.

## Storage drawer

Most cookers include a convenient drawer with ample space for storing baking trays and other cooking accessories.

## Cool Door

Special triple glazing isolates the oven, making it even safer for children and pets. The heat is kept inside, optimising energy consumption by stopping heat escaping from the oven.

## Smooth oven door

Simply removable oven door is free of any notches or edges that could harbour dirt, making cleaning quick and easy.

## MeatProbe

By controlling the temperature inside the meat, the MeatProbe manages the entire process and even activates the alarm when the time is right.

## XXL baking tray

Higher sides of this extra deep baking tray lined with SilverMatte enamel prevent the fat from splattering and burning onto the oven cavity walls.



**EI 647 A21X2** Advanced Line  
Electric cooker with induction hob

**EI 647 A21W2** Advanced Line  
Electric cooker with induction hob



- Colour, stainless steel / Control panel material: Glass and stainless steel / Door material: Glass and stainless steel
- GentleClose door hinge

- Colour: White / Control panel material: Enamel and Glass / Door material: Glass
- GentleClose door hinge

<b>Efficiency</b>	<ul style="list-style-type: none"> <li>- Usable oven volume: 67 l</li> <li>- SuperSize baking area</li> <li>- Surface of the largest baking pan: 1316 cm<sup>2</sup></li> <li>- HomeMADE® modelled on traditional wood-fired bread oven</li> </ul>	<ul style="list-style-type: none"> <li>- Usable oven volume: 67 l</li> <li>- SuperSize baking area</li> <li>- Surface of the largest baking pan: 1316 cm<sup>2</sup></li> <li>- HomeMADE® modelled on traditional wood-fired bread oven</li> </ul>
<b>Control</b>	<ul style="list-style-type: none"> <li>- Ergonomic sinkable knobs</li> <li>- IconTouch</li> </ul>	<ul style="list-style-type: none"> <li>- Ergonomic sinkable knobs</li> <li>- IconTouch</li> </ul>
<b>Hob</b>	<ul style="list-style-type: none"> <li>- Induction hob</li> <li>- Features: BoilControl, prevents pots from boiling over, PowerBoost, All Boost</li> <li>- Cooking surface: 4 induction heating zones</li> <li>- Left front: Ø 18.5 cm, 1.4/2 kW,</li> <li>- Right front: Ø 16.5 cm, 1.2/1.4 kW,</li> <li>- Left behind: Ø 16.5 cm, 1.2/1.4 kW,</li> <li>- Right behind: Ø 20.5 cm, 2/2.3 kW</li> </ul>	<ul style="list-style-type: none"> <li>- Induction hob</li> <li>- Features: BoilControl, prevents pots from boiling over, PowerBoost, All Boost</li> <li>- Cooking surface: 4 induction heating zones</li> <li>- Left front: Ø 18.5 cm, 1.4/2 kW,</li> <li>- Right front: Ø 16.5 cm, 1.2/1.4 kW,</li> <li>- Left behind: Ø 16.5 cm, 1.2/1.4 kW,</li> <li>- Right behind: Ø 20.5 cm, 2/2.3 kW</li> </ul>
<b>Oven</b>	- Multisystem oven BigSpace - 67 l	- Multisystem oven BigSpace - 67 l
<b>Heating types</b>		
<b>Features</b>	<ul style="list-style-type: none"> <li>- Interior light</li> <li>- Baking on different levels at the same time</li> </ul>	<ul style="list-style-type: none"> <li>- Interior light</li> <li>- Baking on different levels at the same time</li> </ul>
<b>Equipment</b>	<ul style="list-style-type: none"> <li>- 1x Deep enameled pan</li> <li>- 2x Shallow enameled pans</li> <li>- 1x Wire shelf / 1x Meat probe</li> <li>- 1x XXL storage drawer</li> <li>- Telescopic oven guides - 1 level</li> </ul>	<ul style="list-style-type: none"> <li>- 1x Deep enameled pan</li> <li>- 2x Shallow enameled pans</li> <li>- 1x Wire shelf / 1x Meat probe</li> <li>- 1x XXL storage drawer</li> <li>- Telescopic oven guides - 1 level</li> </ul>
<b>Safety</b>	<ul style="list-style-type: none"> <li>- Residual heat indicator / Thermoelectric fuse</li> <li>- ChildLock</li> <li>- Dynamic oven cooling plus - DC+</li> <li>- Triple glazed oven door with one heat deflector (CoolDoor)</li> </ul>	<ul style="list-style-type: none"> <li>- Residual heat indicator / Thermoelectric fuse</li> <li>- ChildLock</li> <li>- Dynamic oven cooling plus - DC+</li> <li>- Triple glazed oven door with one heat deflector (CoolDoor)</li> </ul>
<b>EasyCleaning</b>	<ul style="list-style-type: none"> <li>- SilverMatte / Smooth oven door surface</li> <li>- AquaClean</li> </ul>	<ul style="list-style-type: none"> <li>- SilverMatte / Smooth oven door surface</li> <li>- AquaClean</li> </ul>
<b>Technical data</b>	<ul style="list-style-type: none"> <li>- Connected load: 10400 W</li> <li>- Energy consumption: 0.67 kWh (venting), 0.92 kWh (conventional)</li> <li>- Product dimensions (HxWxD): 90 × 60 × 60 cm</li> <li>- EAN code: 3838942047527</li> <li>- Product code: 496934</li> </ul>	<ul style="list-style-type: none"> <li>- Connected load: 10400 W</li> <li>- Energy consumption: 0.67 kWh (venting), 0.92 kWh (conventional)</li> <li>- Product dimensions (HxWxD): 90 × 60 × 60 cm</li> <li>- EAN code: 3838942047534</li> <li>- Product code: 496936</li> </ul>



**EC 637 E14WX** Essential Line  
Electric cooker with ceramic hob





- Colour: White / Control panel material: Enamel
- Door material: Glass
- GentleClose door hinge



**K 637 E14WKE** Essential Line  
Dual fuel cooker with gas hob



- Colour: White / Control panel material: Enamel
- Door material: Glass
- GentleClose door hinge

<b>Efficiency</b>	<ul style="list-style-type: none"> <li>- Usable oven volume: 67 l</li> <li>- SuperSize baking area</li> <li>- Surface of the largest baking pan: 1316 cm<sup>2</sup></li> <li>- HomeMADE® modelled on traditional wood-fired bread oven</li> </ul>	<ul style="list-style-type: none"> <li>- Usable oven volume: 67 l</li> <li>- SuperSize baking area</li> <li>- Surface of the largest baking pan: 1316 cm<sup>2</sup></li> <li>- HomeMADE® modelled on traditional wood-fired bread oven</li> </ul>
<b>Control</b>	<ul style="list-style-type: none"> <li>- Ergonomic sinkable knobs</li> <li>- IconLed</li> </ul>	<ul style="list-style-type: none"> <li>- Ergonomic knobs / IconLed</li> <li>- Single-handed ignition device</li> </ul>
<b>Hob</b>	<ul style="list-style-type: none"> <li>- Glass ceramic hob</li> <li>- Cooking surface: 2 HiLight cooking zones + 2 double HiLight cooking zones</li> <li>- Left front: Ø two ring 21/12 cm, 2.2 kW,</li> <li>- Right front: Ø 18 cm, 1.8 kW,</li> <li>- Left behind: Ø 14.5 cm, 1.2 kW,</li> <li>- Right behind: Ø two ring 18/12 cm, 1.7 kW</li> </ul>	<ul style="list-style-type: none"> <li>- Gas hob / Triple burner / Burner frames number: 2</li> <li>- Cooking surface: 2 standard burners + 1 auxiliary burner + 1 triple burner</li> <li>- Left front: Ø 6.9 cm, 1.9 kW,</li> <li>- Right front: Ø 13.2 cm, 3,5 kW,</li> <li>- Left behind: Ø 6.9 cm, 1.9 kW,</li> <li>- Right behind: Ø 4.6 cm, 1 kW</li> <li>- Type of pan support: Enameled</li> </ul>
<b>Oven</b>	- Multisystem oven BigSpace - 67 l	- Multisystem oven BigSpace - 67 l
<b>Heating types</b>		
<b>Features</b>	<ul style="list-style-type: none"> <li>- Interior light</li> <li>- Baking on different levels at the same time</li> </ul>	<ul style="list-style-type: none"> <li>- Interior light</li> <li>- Baking on different levels at the same time</li> </ul>
<b>Equipment</b>	<ul style="list-style-type: none"> <li>- 1x Deep enameled pan</li> <li>- 2x Shallow enameled pans</li> <li>- 1x Wire shelf</li> <li>- 1x XXL storage drawer</li> <li>- Wire oven guides</li> </ul>	<ul style="list-style-type: none"> <li>- 1x Deep enameled pan</li> <li>- 2x Shallow enameled pans</li> <li>- 1x Wire shelf</li> <li>- 1x XXL storage drawer</li> <li>- Wire oven guides</li> </ul>
<b>Safety</b>	<ul style="list-style-type: none"> <li>- Residual heat indicator</li> <li>- Thermoelectric fuse</li> <li>- Double glazed oven door with one heat deflector (CompactDoor)</li> </ul>	<ul style="list-style-type: none"> <li>- Thermoelectric fuse</li> <li>- Dynamic oven cooling - DC</li> <li>- Double glazed oven door with one heat deflector (CompactDoor)</li> </ul>
<b>EasyCleaning</b>	<ul style="list-style-type: none"> <li>- SilverMatte / Smooth oven door surface</li> <li>- AquaClean</li> </ul>	<ul style="list-style-type: none"> <li>- AquaClean</li> <li>- SilverMatte</li> </ul>
<b>Technical data</b>	<ul style="list-style-type: none"> <li>- Connected load: 10200 W</li> <li>- Energy consumption: 0.82 kWh (venting), 0.92 kWh (conventional)</li> <li>- Product dimensions (HxWxD): 90 × 60 × 60 cm</li> <li>- EAN code: 3838942016967</li> <li>- Product code: 475745</li> </ul>	<ul style="list-style-type: none"> <li>- Energy consumption: 0.82 kWh (venting), 0.92 kWh (conventional)</li> <li>- Product dimensions (HxWxD): 90 × 60 × 60 cm</li> <li>- EAN code: 3838942050138</li> <li>- Product code: 497816</li> </ul>

2  
3 YEAR WARRANTY

**K 613 E17WKD** Essential Line  
Dual fuel cooker with gas hob



- Colour: White
- Control panel material: Enamel
- Door material: Glass

2  
3 YEAR WARRANTY

**GI 612 E17WKA** Essential Line  
Gas cooker with gas hob



- Colour: White
- Control panel material: Enamel
- Door material: Glass

<b>Efficiency</b>	<ul style="list-style-type: none"> <li>- Usable oven volume: 72 l</li> <li>- SuperSize baking area</li> <li>- Surface of the largest baking pan: 1316 cm<sup>2</sup></li> <li>- HomeMADE® modelled on traditional wood-fired bread oven</li> </ul>	<ul style="list-style-type: none"> <li>- Usable oven volume: 48 l</li> </ul>
<b>Control</b>	<ul style="list-style-type: none"> <li>- Ergonomic knobs</li> <li>- Electric ignition of gas burners</li> </ul>	<ul style="list-style-type: none"> <li>- Ergonomic knobs</li> <li>- Electric ignition of gas burners</li> </ul>
<b>Hob</b>	<ul style="list-style-type: none"> <li>- Gas hob / Burner frames number: 2</li> <li>- Cooking surface: 1 auxiliary burner + 1 large burner + 2 standard burners</li> <li>- Left front: Ø 6.9 cm, 1.9 kW,</li> <li>- Right front: Ø 9.4 cm, 3 kW,</li> <li>- Left behind: Ø 6.9 cm, 1.9 kW,</li> <li>- Right behind: Ø 4.6 cm, 1 kW</li> <li>- Type of pan support: Enameled</li> </ul>	<ul style="list-style-type: none"> <li>- Gas hob / Burner frames number: 2</li> <li>- Cooking surface: 1 auxiliary burner + 1 large burner + 2 standard burners</li> <li>- Left front: Ø 6.9 cm, 1.9 kW,</li> <li>- Right front: Ø 9.4 cm, 3 kW,</li> <li>- Left behind: Ø 6.9 cm, 1.9 kW,</li> <li>- Right behind: Ø 4.6 cm, 1 kW</li> <li>- Type of pan support: Enameled</li> </ul>
<b>Oven</b>	- Conventional oven - 72 l	- Gas oven - 48 l
<b>Heating types</b>		
<b>Features</b>	- Interior light	- Interior light
<b>Equipment</b>	<ul style="list-style-type: none"> <li>- 1x Deep enameled pan</li> <li>- 2x Shallow enameled pans</li> <li>- 1x Wire shelf</li> <li>- 1x XXL storage drawer</li> <li>- Wire oven guides</li> </ul>	<ul style="list-style-type: none"> <li>- 1x Deep enameled pan</li> <li>- 2x Shallow aluminium pan</li> <li>- 1x Wire shelf</li> <li>- Wire oven guides</li> </ul>
<b>Safety</b>	<ul style="list-style-type: none"> <li>- Thermoelectric fuse</li> <li>- Double glazed oven door with one heat deflector (CompactDoor)</li> </ul>	- Double glazed oven door with one heat deflector (CompactDoor)
<b>EasyCleaning</b>	<ul style="list-style-type: none"> <li>- AquaClean</li> <li>- SilverMatte</li> </ul>	<ul style="list-style-type: none"> <li>- AquaClean</li> <li>- SilverMatte</li> </ul>
<b>Technical data</b>	<ul style="list-style-type: none"> <li>- Energy consumption: 0.88 kWh (conventional)</li> <li>- Product dimensions (HxWxD): 90 × 60 × 60 cm</li> <li>- EAN code: 3838942050121</li> <li>- Product code: 497815</li> </ul>	<ul style="list-style-type: none"> <li>- Energy consumption: 1.67 kWh (conventional)</li> <li>- Energy consumption gas oven: 6.01 MJ</li> <li>- Product dimensions (HxWxD): 90 × 60 × 60 cm</li> <li>- EAN code: 3838942083358</li> <li>- Product code: 518358</li> </ul>



## GI 52108 AW

### Gas cooker with gas hob

**B**

Energy  
Class



50  
cm

90  
cm

46 l



- Colour: White
- Control panel material: Enamel
- Door material: Glass

<b>Efficiency</b>	<ul style="list-style-type: none"> <li>- Usable oven volume: 46 l</li> <li>- Surface of the largest baking pan: 1230 cm<sup>2</sup></li> </ul>
<b>Control</b>	<ul style="list-style-type: none"> <li>- Ergonomic knobs</li> <li>- Two-handed ignition device</li> </ul>
<b>Hob</b>	<ul style="list-style-type: none"> <li>- Gas hob</li> <li>- Burner frames number: 2</li> <li>- Cooking surface: 1 auxiliary burner + 1 large burner + 2 standard burners</li> <li>- Left front: Ø 5.5 cm, 1 kW,</li> <li>- Right front: Ø 7.5 cm, 1.75 kW,</li> <li>- Left behind: Ø 7.5 cm, 1.75 kW,</li> <li>- Right behind: Ø 10 cm, 2.7 kW</li> </ul>
<b>Oven</b>	<ul style="list-style-type: none"> <li>- Gas oven - 46 l</li> </ul>
<b>Heating types</b>	 
<b>Features</b>	<ul style="list-style-type: none"> <li>- Interior light</li> </ul>
<b>Equipment</b>	<ul style="list-style-type: none"> <li>- 1 x Deep enameled pan</li> <li>- 1 x Wire shelf</li> <li>- 1 x Pan holder</li> <li>- Wire oven guides</li> </ul>
<b>Safety</b>	<ul style="list-style-type: none"> <li>- Thermoelectric fuse</li> <li>- Double glazed oven door with one heat deflector (CompactDoor)</li> </ul>
<b>EasyCleaning</b>	<ul style="list-style-type: none"> <li>- Eco enamel (oven and baking tray)</li> </ul>
<b>Technical data</b>	<ul style="list-style-type: none"> <li>- Energy consumption: 1.86 kWh (conventional)</li> <li>- Energy consumption gas oven: 6.7 MJ</li> <li>- Product dimensions (HxWxD): 90 × 50 × 60.5 cm</li> <li>- EAN code: 3838942523045</li> <li>- Product code: 241211</li> </ul>



### E 617 E17WKA Essential Line

Electric cooker with solid-plate hob

**A**

Energy Class



- Colour: White
- Control panel material: Enamel
- Door material: Glass



### E 52108 AW

Electric cooker with solid-plate hob

**B**

Energy Class



- Colour: White
- Control panel material: Enamel
- Door material: Glass

<b>Efficiency</b>	<ul style="list-style-type: none"> <li>- Usable oven volume: 67 l</li> <li>- SuperSize baking area</li> <li>- Surface of the largest baking pan: 1316 cm<sup>2</sup></li> <li>- HomeMADE® modelled on traditional wood-fired bread oven</li> </ul>	<ul style="list-style-type: none"> <li>- Usable oven volume: 53 l</li> <li>- Surface of the largest baking pan: 1230 cm<sup>2</sup></li> </ul>
<b>Control</b>	- Ergonomic knobs	- Ergonomic knobs
<b>Hob</b>	<ul style="list-style-type: none"> <li>- Electric hob</li> <li>- Cooking surface: 3 fast electric hobs + 1 standard hob with temperature restainer</li> <li>- Left front: Ø 22 cm, 2 kW,</li> <li>- Right front: Ø 14.5 cm, 1.5 kW,</li> <li>- Left behind: Ø 14.5 cm, 1.5 kW,</li> <li>- Right behind: Ø 18 cm, 2 kW</li> </ul>	<ul style="list-style-type: none"> <li>- Electric hob</li> <li>- Cooking surface: 1 fast electric hob + 2 standard electric hobs + 1 standard hob with temperature restrainer</li> <li>- Left front: Ø 18 cm, 2 kW,</li> <li>- Right front: Ø 14.5 cm, 1 kW,</li> <li>- Left behind: Ø 14.5 cm, 1 kW,</li> <li>- Right behind: Ø 18 cm, 1.5 kW</li> </ul>
<b>Oven</b>	- Multisystem oven BigSpace - 67 l	- Conventional - 53 l
<b>Heating types</b>		
<b>Features</b>	<ul style="list-style-type: none"> <li>- Interior light</li> <li>- Baking on different levels at the same time</li> </ul>	- Interior light
<b>Equipment</b>	<ul style="list-style-type: none"> <li>- 1x Deep enameled pan</li> <li>- 2x Shallow enameled pan</li> <li>- 1x Wire shelf</li> <li>- Wire oven guides</li> </ul>	<ul style="list-style-type: none"> <li>- 1x Deep enameled pan</li> <li>- 1 x Wire shelf</li> <li>- 1 x Pan holder</li> <li>- Wire oven guides</li> </ul>
<b>Safety</b>	<ul style="list-style-type: none"> <li>- Thermoelectric fuse</li> <li>- Triple glazed oven door with one heat deflector (CoolDoor)</li> </ul>	- Double glazed oven door with one heat deflector (CompactDoor)
<b>EasyCleaning</b>	<ul style="list-style-type: none"> <li>- SilverMatte / Smooth oven door surface</li> <li>- AquaClean</li> </ul>	<ul style="list-style-type: none"> <li>- AquaClean</li> <li>- Eco enamel (oven and baking tray)</li> </ul>
<b>Technical data</b>	<ul style="list-style-type: none"> <li>- Connected load: 10300 W</li> <li>- Energy consumption: 0.82 kWh (venting), 0.92 kWh (conventional)</li> <li>- Product dimensions (HxWxD): 90 × 60 × 60 cm</li> <li>- EAN code: 3838942016981</li> <li>- Product code 475743</li> </ul>	<ul style="list-style-type: none"> <li>- Connected load: 7400 W</li> <li>- Energy consumption: 0.92 kWh (conventional)</li> <li>- Product dimensions (HxWxD): 90 × 50 × 60.5 cm</li> <li>- EAN code: 3838942523021</li> <li>- Product code: 241209</li> </ul>







## THE COOL SIDE OF YOU

Vintage design, with a long list of colours to choose from, makes this refrigerator one of the highlights of your home. As a design item you can easily place it anywhere you like. Perhaps in your romantic kitchen, in your chic urban nest, even your funky loft. Each Retro refrigerator is striking, boasts optimal storage configurations, and all the features one would expect from a high-end appliance. Whatever the colour, these modern icons are an instant hit wherever they pop up.



### IonAir with MultiFlow 360° Ideal microclimate on every shelf

Advanced technology in the refrigerators emulates the natural process of ionization to keep the food fresh longer. Negatively charged ions generated by the appliance continuously refresh the air to mimic a natural microclimate, thus creating the ideal environment for fresh food. The MultiFlow 360° ventilation system evenly distributes the ionized air through 14 ventilation slots to maintain constant temperature on every shelf.



### IonAir with DynamiCooling Even temperature distribution in the refrigerator compartment

Advanced fan system with dynamic cooling evenly distributes the ionized air and equalizes the temperature throughout the entire refrigerator. Air enriched with extra negative ions mimics the natural microclimate that keeps the food fresh for longer. Moreover, any type of food can be placed on any shelf in the fridge as there are no temperature differences.



### NoFrost Plus No more tedious defrosting

One of the best cooling systems in the market, installed in the freezer compartment, prevents the accumulation of ice and frost to keep the power consumption low, while in the refrigerator compartment, it maintains an ideal microclimate for fresh food. Circulation of ionized air prevents the food from drying out and retains its vitamins and minerals.



### AdaptTech A refrigerator that recognizes your habits

This smart system was devised to maintain the optimum temperature in the refrigerator regardless of how frequently you open the door. When the door is opened, the temperature suddenly rises and the food is exposed to a thermal shock which in turn causes it to perish sooner. The refrigerator continuously monitors and analyzes the way you use it. Thus, it can predict when you will open the fridge door and just before you do, it decreases the temperature by 1 or 2 °C to make sure constant temperature is maintained and that the food stays fresh and full of nutrients.



### LedLight

Well-arranged and efficient fridge

Power saving LED lighting fixtures in a form of strip are highly energy-efficient, have a notably longer useful life and consume less power.



### PullOut shelves

Easy access to food

Sliding shelves for quick and easy access to food, which hold up to 22 kg of food.



### SimpleSlide shelves

For both tall and short bottles

An especially practical mechanism which allows movement of shelves up and down.



### FreshZone drawer

Fresh as if straight from nature

The drawer with the lowest temperature in the refrigerator is ideal for storing meat, fish, fruit, and vegetables. It will preserve the food's freshness, aroma, colour, and flavour for much longer.



### ZeroZone drawer

Fresh as if straight from the sea

The drawer with temperature around 0 °C is ideal for storing fresh or marinated meat, fish and seafood. It extends the freshness of delicate food and keeps its natural juiciness and nutrients.



### XtremeFreeze drawer

Freezing in a flash

Rapid freezing at extremely low temperatures. The shock-approach preserves all nutrients and the flavour of the food.



## MultiBox

Multi-functional, practical box

The multi-purpose bin with a cover in the refrigerator door can be used for storing cheese, onions, and other food with a pungent smell. It keeps the food fresh and protects it from drying, while the silicone cover can be used as an egg or ice tray.



## FastFreeze

Rapid freezing

Function inside the freezer for fast freezing of food, perfect for restocking.



## CrispZone drawer featuring HumidityControl

Just like garden-fresh

CrispZone is one of the largest fruit and vegetables bins in the market. Low temperature and the option to adjust the humidity extend the freshness of your produce.



## FrostLess

Less ice, more energy saving

Improved insulation effectively reduces the accumulation of frost on the food and ice in the appliance interior. This means less tedious defrosting and a lower electricity bill.



## Top energy efficiency

All Gorenje refrigerators are highly energy-efficient. Excellent thermal insulation and door sealing and electronic or mechanical control efficiently reduce power consumption. Gorenje A+++ refrigerators verified by the Energy Saving Trust cost less than £2 to run every month, or just £3 for A++.

(Based on ORB153, RF60309, ORK193, ONRK193. Figures are based on the EU Energy Label energy consumption. Average electricity price of 13.86p/kWh. Correct as of January 2016).



## Inverter Compressor

Steady, silent, and durable

InverterCompressor are more silent, have a longer useful life and they are more economical compared to those with a conventional compressor. Whenever the temperature in the fridge interior rises as a result of door opening, the inverter compressor delivers rapid and effective cooling to prevent the food from spoiling.



## EcoMode

Energy savings

In case of prolonged absence, the fridge can be set to operate in power-saving mode as the door is closed all the time.



## SuperCool

Rapid cooling after weekly shopping

The intensive cooling function drops the refrigerator temperature by nearly a half of its usual. Ideal for rapid cooling of food after major shopping trips.



## Fan

Fan assisted cooling

A fan propels the air to make sure the temperature is even throughout the refrigerator. This improves cooling and prevents accumulation of condensate, thus maintaining optimum environment for lasting freshness of all types of food.



## ONRK 193 C Gorenje Retro Collection Freestanding No Frost fridge freezer



- Colour: Cream
- Right door opening
- Door material: Plastic
- Climate class: SN, ST, N, T

<b>Efficiency</b>	<ul style="list-style-type: none"> <li>- Inverter compressor</li> <li>- Total gross/net volume: 334 / 307 l</li> <li>- Capacity of cooling compartment: gross/net: 231 / 222 l</li> <li>- Capacity of freezer compartment: gross/net: 103 / 85 l</li> <li>- Freezing capacity in 24 hours: 8 kg / 24h</li> <li>- Power cut safe time: 18 h</li> </ul>
<b>Control</b>	<ul style="list-style-type: none"> <li>- Type of display: LED</li> <li>- Sound alarm for open door</li> <li>- Sound and visual signal for high temperature in refrigerator: white signal</li> </ul>
<b>Features</b>	<ul style="list-style-type: none"> <li>- IonAir with MultiFlow 360 °</li> <li>- AdaptTech cooling: Memorizing intelligent system</li> <li>- NoFrost Plus / SuperCool / FastFreeze / Saving programme EcoMode</li> <li>- XtremeFreeze: very intensive freezing in the upper freezer drawer</li> </ul>
<b>Equipment of refrigerator</b>	<ul style="list-style-type: none"> <li>- Egg/Ice bin: Egg/Ice bin: 1 x 7</li> <li>- SimpleSlide height adjustable door shelves: 2</li> <li>- Type of interior light: LED strip</li> <li>- 4 glass shelves</li> <li>- Bottle rack</li> <li>- Bottle shelf with fixed trap</li> <li>- MultiBox for butter and cheese</li> <li>- CrispZone with HumidityControl: big vegetable drawer with humidity regulation</li> <li>- ZeroZone drawer</li> </ul>
<b>Equipment of freezer</b>	<ul style="list-style-type: none"> <li>- 1 XXL SpaceBox drawer</li> <li>- 2 drawers for freezing</li> </ul>
<b>Technical data</b>	<ul style="list-style-type: none"> <li>- Energy consumption kWh/24h: 0,46 kWh</li> <li>- Level of noise (max.): 42 dB(A)re 1 pW</li> <li>- Product dimensions (HxWxD): 194 × 60 × 64 cm</li> <li>- EAN code: 3838942104954</li> <li>- Product code: 538883</li> </ul>



**ONRK 193 R**  
 - Colour: Burgundy  
 - EAN code: 3838942104923  
 - Product code: 538880



**ONRK 193 BK**  
 - Colour: Black  
 - EAN code: 3838942104930  
 - Product code: 538881



**ONRK 193 BL**  
 - Colour: Baby Blue  
 - EAN code: 3838942104947  
 - Product code: 538882



**ORK 193 R** Gorenje Retro Collection  
Freestanding fridge freezer



- Colour: Burgundy
- Right door opening
- Door material: Steel sheet
- Climate class: SN, ST, N, T

<b>Efficiency</b>	<ul style="list-style-type: none"> <li>- 1 compressor</li> <li>- Total gross/net volume: 326 / 322 l</li> <li>- Capacity of cooling compartment: gross/net: 229 / 227 l</li> <li>- Capacity of freezer compartment: gross/net: 97 / 95 l</li> <li>- Freezing capacity in 24 hours: 4,5 kg / 24h</li> <li>- Power cut safe time: 30 h</li> </ul>
<b>Control</b>	<ul style="list-style-type: none"> <li>- Electronic control</li> </ul>
<b>Features</b>	<ul style="list-style-type: none"> <li>- AdaptTech cooling: Memorizing intelligent system</li> <li>- FrostLess: Less ice building in the freezer</li> <li>- IonAir with DynamiCooling</li> <li>- FastFreeze</li> </ul>
<b>Equipment of refrigerator</b>	<ul style="list-style-type: none"> <li>- Egg/Ice bin: Egg/Ice bin: 1 x 7</li> <li>- SimpleSlide height adjustable door shelves: 2</li> <li>- Type of interior light: LED strip</li> <li>- 4 glass shelves</li> <li>- Bottle rack</li> <li>- Bottle shelf with fixed trap</li> <li>- MultiBox for butter and cheese</li> <li>- CrispZone with HumidityControl: big vegetable drawer with humidity regulation</li> <li>- FreshZone drawer</li> </ul>
<b>Equipment of freezer</b>	<ul style="list-style-type: none"> <li>- 1 XXL SpaceBox drawer</li> <li>- 2 drawers for freezing</li> </ul>
<b>Technical data</b>	<ul style="list-style-type: none"> <li>- Energy consumption kWh/24h: 0,423 kWh</li> <li>- Level of noise (max.): 40 dB(A)re 1 pW</li> <li>- Product dimensions (HxWxD): 194 x 60 x 64 cm</li> <li>- EAN code: 3838942093326</li> <li>- Product code: 528545</li> </ul>



**ORK 193 C**  
- Colour: Cream  
- EAN code: 3838942093333  
- Product code: 528546



**ORK 193 X**  
Colour: Silver  
- EAN code: 3838942092596  
- Product code: 527606



**ORK 193 BK**  
- Colour: Black  
- EAN code: 3838942093340  
- Product code: 528547



**ORK 193 CO**  
- Colour: Royal Coffee  
- EAN code: 3838942102493  
- Product code: 536696



**ORK 193 RD**  
- Colour: Fiery Red  
- EAN code: 3838942092589  
- Product code: 527664



**ORK 193 GR**  
- Colour: Lime Green  
- EAN code: 3838942092619  
- Product code: 527686



**ORK 193 O**  
- Colour: Juicy Orange  
- EAN code: 3838942092602  
- Product code: 527678



**ORK 193 BL**  
- Colour: Baby Blue  
- EAN code: 3838942092923  
- Product code: 527688



## ORK 193 BK-L Gorenje Retro Collection Freestanding fridge freezer

**A<sup>++</sup>** Energy Class

\*\*\*

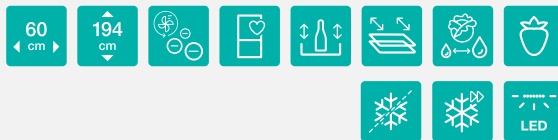

- Colour: Black
- Left door opening
- Door material: Steel sheet
- Climate class: SN, ST, N, T

<b>Efficiency</b>	<ul style="list-style-type: none"> <li>- 1 compressor</li> <li>- Total gross/net volume: 326 / 322 l</li> <li>- Capacity of cooling compartment: gross/net: 229 / 227 l</li> <li>- Capacity of freezer compartment: gross/net: 97 / 95 l</li> <li>- Freezing capacity in 24 hours: 4,5 kg / 24h</li> <li>- Power cut safe time: 30 h</li> </ul>
<b>Control</b>	<ul style="list-style-type: none"> <li>- Electronic control</li> </ul>
<b>Features</b>	<ul style="list-style-type: none"> <li>- AdaptTech cooling: Memorizing intelligent system</li> <li>- FrostLess: Less ice building in the freezer</li> <li>- IonAir with DynamiCooling</li> <li>- FastFreeze</li> </ul>
<b>Equipment of refrigerator</b>	<ul style="list-style-type: none"> <li>- Egg/Ice bin: Egg/Ice bin: 1 x 7</li> <li>- SimpleSlide height adjustable door shelves: 2</li> <li>- Type of interior light: LED strip</li> <li>- 4 glass shelves</li> <li>- Bottle rack</li> <li>- Bottle shelf with fixed trap</li> <li>- MultiBox for butter and cheese</li> <li>- CrispZone with HumidityControl: big vegetable drawer with humidity regulation</li> <li>- FreshZone drawer</li> </ul>
<b>Equipment of freezer</b>	<ul style="list-style-type: none"> <li>- 1 XXL SpaceBox drawer</li> <li>- 2 drawers for freezing</li> </ul>
<b>Technical data</b>	<ul style="list-style-type: none"> <li>- Energy consumption kWh/24h: 0,423 kWh</li> <li>- Level of noise (max.): 40 dB(A)re 1 pW</li> <li>- Product dimensions (HxWxD): 194 x 60 x 64 cm</li> <li>- EAN code: 3838942087677</li> <li>- Product code: 521885</li> </ul>



**ORK 193 C-L**  
 - Colour: Cream  
 - EAN code: 3838942087684  
 - Product code: 521899



**ORK 193 R-L**  
 - Colour: Burgundy  
 - EAN code: 3838942087660  
 - Product code: 521884



**ORB 153 O** Gorenje Retro Collection  
Freestanding refrigerator with IceBox



- Colour: Juicy Orange
- Right door opening
- Door material: Plastic
- Climate class: SN, ST, N, T

<b>Efficiency</b>	<ul style="list-style-type: none"> <li>- 1 compressor</li> <li>- Total gross/net volume: 260 / 254 l</li> <li>- Capacity of cooling compartment: gross/net: 235 / 229 l</li> <li>- Capacity of freezer compartment: gross/net: 25 / 25 l</li> <li>- Freezing capacity in 24 hours: 2 kg / 24h</li> <li>- Power cut safe time: 17 h</li> </ul>
<b>Control</b>	<ul style="list-style-type: none"> <li>- Mechanical control</li> </ul>
<b>Features</b>	<ul style="list-style-type: none"> <li>- IonAir with DynamiCooling</li> </ul>
<b>Equipment of refrigerator</b>	<ul style="list-style-type: none"> <li>- Egg/Ice bin: Egg/Ice bin: 1 x 7</li> <li>- SimpleSlide height adjustable door shelves: 3</li> <li>- Type of interior light: LED strip</li> <li>- 4 glass shelves</li> <li>- Bottle rack</li> <li>- Bottle shelf with fixed trap</li> <li>- MultiBox for butter and cheese</li> <li>- CrispZone with HumidityControl: big vegetable drawer with humidity regulation</li> <li>- FreshZone drawer</li> </ul>
<b>Equipment of freezer</b>	<ul style="list-style-type: none"> <li>- 1 compartment with door for frozen food</li> </ul>
<b>Technical data</b>	<ul style="list-style-type: none"> <li>- Energy consumption kWh/24h: 0,339 kWh</li> <li>- Level of noise (max.): 40 dB(A)re 1 pW</li> <li>- Product dimensions (HxWxD): 154 x 60 x 64 cm</li> <li>- EAN code: 3838942092695</li> <li>- Product code: 527317</li> </ul>



**ORB 153 GR**  
- Colour: Lime Green  
- EAN code: 3838942092688  
- Product code: 527316



**ORB 153 BL**  
- Colour: Baby Blue  
- EAN code: 3838942094903  
- Product code: 530640



**ORB 153 R**  
- Colour: Burgundy  
- EAN code: 3838942094910  
- Product code: 530642



**ORB 153 RD**  
- Colour: Fiery Red  
- EAN code: 3838942093371  
- Product code: 528605



**ORB 153 BK**  
- Colour: Black  
- EAN code: 3838942093364  
- Product code: 528602



**ORB 153 X**  
- Colour: Silver  
- EAN code: 3838942092701  
- Product code: 527319



**ORB 153 C**  
- Colour: Cream  
- EAN code: 3838942093357  
- Product code: 528548



**ORB 153 CO**  
- Colour: Royal Coffee  
- EAN code: 3838942102486  
- Product code: 536695





### ORB 153 C-L Gorenje Retro Collection Freestanding refrigerator with IceBox



- Colour: Cream
- Left door opening
- Door material: Plastic
- Climate class: SN, ST, N, T

<b>Efficiency</b>	<ul style="list-style-type: none"> <li>- 1 compressor</li> <li>- Total gross/net volume: 260 / 254 l</li> <li>- Capacity of cooling compartment: gross/net: 235 / 229 l</li> <li>- Capacity of freezer compartment: gross/net: 25 / 25 l</li> <li>- Freezing capacity in 24 hours: 2 kg / 24h</li> <li>- Power cut safe time: 17 h</li> </ul>
<b>Control</b>	- Mechanical control
<b>Features</b>	- IonAir with DynamiCooling
<b>Equipment of refrigerator</b>	<ul style="list-style-type: none"> <li>- Egg/Ice bin: Egg/Ice bin: 1 x 7</li> <li>- SimpleSlide height adjustable door shelves: 3</li> <li>- Type of interior light: LED strip</li> <li>- 4 glass shelves</li> <li>- Bottle rack</li> <li>- Bottle shelf with fixed trap</li> <li>- MultiBox for butter and cheese</li> <li>- CrispZone with HumidityControl: big vegetable drawer with humidity regulation</li> <li>- FreshZone drawer</li> </ul>
<b>Equipment of freezer</b>	- 1 compartment with door for frozen food
<b>Technical data</b>	<ul style="list-style-type: none"> <li>- Energy consumption kWh/24h: 0,339 kWh</li> <li>- Level of noise (max.): 40 dB(A)re 1 pW</li> <li>- Product dimensions (HxWxD): 154 × 60 × 64 cm</li> <li>- EAN code: 3838942087226</li> <li>- Product code: 521303</li> </ul>



**ORB 153 BL-L**  
- Colour: Baby Blue  
- EAN code: 3838942092671  
- Product code: 527315



**ORB 153 BK-L**  
- Colour: Black  
- EAN code: 3838942086618  
- Product code: 521302



**ORB 153 R-L**  
- Colour: Burgundy  
- EAN code: 3838942092718  
- Product code: 527320



**ORB 153 RD-L**  
- Colour: Fiery red  
- EAN code: 3838942086601  
- Product code: 521301



**RF 60309 OC** Gorenje Retro Collection  
Freestanding fridge freezer



- Colour: Cream
- Door opening: Right
- Door material: Steel sheet
- Climate class: SN, ST, N, T

<b>Efficiency</b>	<ul style="list-style-type: none"> <li>- 1 compressor</li> <li>- Total gross/net volume: 296 / 294 l</li> <li>- Capacity of cooling compartment: gross/net: 231 / 229 l</li> <li>- Capacity of freezer compartment: gross/net: 65 / 65 l</li> <li>- Freezing capacity in 24 hours: 4.5 kg / 24h</li> <li>- Power cut safe time: 22 h</li> </ul>
<b>Control</b>	<ul style="list-style-type: none"> <li>- Mechanical control</li> </ul>
<b>Features</b>	<ul style="list-style-type: none"> <li>- Fan-assisted cooling in fridge</li> <li>- SuperCool</li> <li>- FastFreeze</li> </ul>
<b>Equipment of refrigerator</b>	<ul style="list-style-type: none"> <li>- Type of interior light: LED</li> <li>- 4 glass shelves</li> <li>- Bottle rack</li> <li>- Dairy shelf</li> <li>- Flexible egg tray (12x)</li> <li>- Deep door two-partition bottle shelf with fixed trap</li> <li>- Large crisper pan for vegetables and fruit</li> </ul>
<b>Equipment of freezer</b>	<ul style="list-style-type: none"> <li>- 1 wire shelf in freezer department</li> <li>- 1 compartment with door for frozen food</li> <li>- 1 ice tray</li> </ul>
<b>Technical data</b>	<ul style="list-style-type: none"> <li>- Energy consumption kWh/24h: 0.583 kWh</li> <li>- Energy consumption kWh/year: 213 kWh</li> <li>- Level of noise (max.): 39 dB(A)re 1 pW</li> <li>- Product dimensions (HxWxD): 173.4 x 60 x 64 cm</li> <li>- EAN code: 3838942899386</li> <li>- Product code: 444708</li> </ul>



**RF 60309 OR**  
- Colour: Burgundy  
- EAN code: 3838942899256  
- Product code: 444721



**RF 60309 OX**  
- Colour: Silver  
- EAN code: 3838942028250  
- Product code: 481864



**RF 60309 OBK**  
- Colour: Black  
- EAN code: 3838942899379  
- Product code: 444709



**RF 60309 OCO**  
- Colour: Royal Coffee  
- EAN code: 3838942899515  
- Product code: 444695



## RF 60309 OR-L Gorenje Retro Collection Freestanding fridge freezer

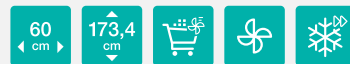

- Colour: Burgundy
- Door opening: Left
- Door material: Steel sheet
- Climate class: SN, ST, N, T

<b>Efficiency</b>	<ul style="list-style-type: none"> <li>- 1 compressor</li> <li>- Total gross/net volume: 296 / 294 l</li> <li>- Capacity of cooling compartment: gross/net: 231 / 229 l</li> <li>- Capacity of freezer compartment: gross/net: 65 / 65 l</li> <li>- Freezing capacity in 24 hours: 4.5 kg / 24h</li> <li>- Power cut safe time: 22 h</li> </ul>
<b>Control</b>	- Mechanical control
<b>Features</b>	<ul style="list-style-type: none"> <li>- Fan-assisted cooling in fridge</li> <li>- SuperCool</li> <li>- FastFreeze</li> </ul>
<b>Equipment of refrigerator</b>	<ul style="list-style-type: none"> <li>- Type of interior light: LED</li> <li>- 4 glass shelves</li> <li>- Bottle rack</li> <li>- Dairy shelf</li> <li>- Flexible egg tray (12x)</li> <li>- Deep door two-partition bottle shelf with fixed trap</li> <li>- Large crisper pan for vegetables and fruit</li> </ul>
<b>Equipment of freezer</b>	<ul style="list-style-type: none"> <li>- 1 wire shelf in freezer department</li> <li>- 1 compartment with door for frozen food</li> <li>- 1 ice tray</li> </ul>
<b>Technical data</b>	<ul style="list-style-type: none"> <li>- Energy consumption kWh/24h: 0.583 kWh</li> <li>- Energy consumption kWh/year: 213 kWh</li> <li>- Level of noise (max.): 39 dB(A)re 1 pW</li> <li>- Product dimensions (HxWxD): 173.4 × 60 × 64 cm</li> <li>- EAN code: 838942934865</li> <li>- Product code: 416682</li> </ul>



### RF 60309 OBK-L

- Colour: Black
- EAN code: 3838942934858
- Product code: 416681



### RF 60309 OC-L

- Colour: Cream
- EAN code: 3838942898716
- Product code: 444776





# GUARDIANS OF VITAMINS

## Cooling Appliances

Gorenje refrigerators, freezers and fridge freezers are the hub of every kitchen. They are tasked with a simple mission – make sure your favourite food is always available. But Gorenje cooling appliances can do much more. They feature smart technologies to mimic the conditions similar to those found in nature, which keeps the food fresh, tasty, and full of vital nutrients for longer. On the inside, they are thoughtfully organized to allow the user optimum view and plenty of space for storage of even larger amounts. On the outside, their superior design introduces a welcome visual accent to any home. Last but not least, they are notoriously charming with their silent and economical operation, and convincing durability.



## IonAir with the MultiFlow 360° function

Ideal microclimate on every shelf

Advanced technology in the refrigerators emulates the natural process of ionization to keep the food fresh longer. Negatively charged ions generated by the appliance continuously refresh the air to mimic a natural microclimate, thus creating the ideal environment for fresh food. The MultiFlow 360° ventilation system evenly distributes the ionized air through 14 ventilation slots to maintain constant temperature on every shelf.



Natural microclimate inside refrigerator

Bad food storage





## AdaptTech

A refrigerator that recognizes your habits

This smart system was devised to maintain the optimum temperature in the refrigerator regardless of how frequently you open the door. When the door is opened, the temperature suddenly rises and the food is exposed to a thermal shock which in turn causes it to perish sooner. The refrigerator

continuously monitors and analyzes the way you use it. Thus, it can predict when you will open the fridge door and just before you do, it decreases the temperature by 1 or 2 °C to make sure constant temperature is maintained and that the food stays fresh and full of nutrients.

Temperature [ °C ]

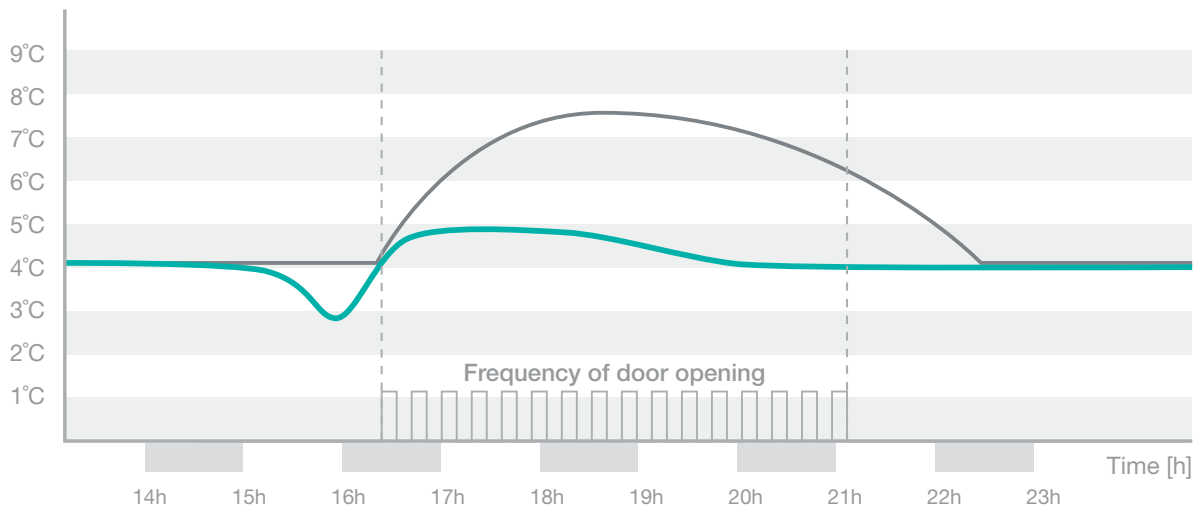

— Line of temperature oscillations in a regular refrigerator

— Line of temperature oscillations in refrigerator with AdaptTech technology



## NoFrost Plus

No more tedious defrosting

One of the best cooling systems in the market, installed in the freezer compartment, prevents the accumulation of ice and frost to keep the power consumption low, while in the refrigerator compartment, it maintains an ideal microclimate for fresh food. Circulation of ionized air prevents the food from drying out and retains its vitamins and minerals.



# The big party can start



## ConvertActive fridge freezer

The big party can start

The fridge freezer only takes a simple press of a button to turn the freezer compartment into a refrigerator compartment, affording more space for storage of snacks or beverages.



NRC 6192 TXUK



## CrispActive drawer with the VitaLight

The fruit and vegetables bin with the special VitaLight extends the freshness of the food. A spectrum of orange light slows down the natural process of ripening in the fruits and vegetables to retain vitamins and minerals.



## FreshActive drawer

This drawer is ideal for storing meat, fish, and seafood. The temperature is a few degrees lower than in the remaining part of the refrigerator compartment, which considerably extends its freshness.





### CrispZone drawer featuring HumidityControl Just like garden-fresh

CrispZone is one of the largest fruit and vegetable bins in the market. Low temperature and the option to adjust the humidity extend the freshness of your produce.



### ZeroZone drawer Fresh as if straight from the sea

Keeping the temperature around 0 °C, this drawer is ideal for storing fresh or marinated meat, fish and seafood. It extends the freshness of delicate food and keeps its natural juiciness and nutrients.



### XtremeFreeze drawer Freezing in a flash

When this function is activated, the food placed in a special drawer in the freezer compartment will be frozen in half the usual time. Rapid freezing at extremely low temperatures below -30 °C leads to formation of microcrystals that, unlike in case of slow freezing, do not damage the cellular structure of the food. The shock-approach to freezing thus preserves all nutrients and the flavour of the food. After approximately 1 day, the function is automatically switched off and the temperature in the drawer returns to the initial setting.



### XXL SpaceBox Enough space to store a turkey

This freezer compartment drawer is the largest in the appliance and it is ideal for storing large items like a turkey, several pizzas, or even cakes.





## SlotIn

Owing to the functionality of opening the refrigerator door at a right angle, all shelves and bins can be fully pulled out. This solution is ideal for refrigerators placed against a side wall, or adjacent to a countertop or another appliance.



## SuperCool

The intensive cooling function drops the refrigerator temperature to 3 °C, which is lower than usual by nearly a half. Combined with large refrigerator compartment volume, this temperature is ideal for rapid cooling of food after major shopping trips. After six hours, the function is switched off automatically and the refrigerator compartment temperature returns to the initial setting.



## PullOut shelves

Shelves on extendible guides allow quick and easy access to food at the back of the fridge. The tempered glass shelves are highly durable and will carry up to 22 kilograms of food.



## FrostLess

Improved insulation effectively reduces the accumulation of frost on the food and ice in the appliance interior. This means less tedious defrosting and a lower electricity bill.



## FastFreeze

The FastFreeze function freezes the food at -24 °C to preserve most of the minerals in the food. After approximately 2 days, the function is switched off automatically and the freezer compartment temperature returns to the initial setting.



## MultiBox

The multi-purpose bin with a cover in the refrigerator door can be used for storing cheese, onions, and other food with a pungent smell. It keeps the food fresh and protects it from drying, while the silicone cover can be used as an egg or ice tray.



## SimpleSlide shelves

Height-adjustable shelves in the refrigerator door can be easily moved up or down to accommodate up to 5 kilograms of food of different shapes or sizes.



## IonAir with DynamiCooling

Advanced fan system with dynamic cooling evenly distributes the ionized air and equalizes the temperature throughout the entire refrigerator. Air enriched with extra negative ions mimics the natural microclimate that keeps the food fresh for longer. Moreover, the any type of food can be placed on any shelf in the fridge as there are not temperature differences.



## LedLight

LED lighting in refrigerators provides excellent and highly efficient illumination. Its useful life is thirty times as long as that of conventional light bulbs, and it saves up to ten times as much power.



## Fridge freezers with a height of 2m

These appliances are ideal for larger families. In addition to more space, they also feature all systems for maintaining a natural microclimate and steady temperature.



## EcoMode

In case of prolonged absence, the fridge can be set to operate in power-saving mode as the door is closed all the time.



## Top energy efficiency

All Gorenje refrigerators are highly energy-efficient. Excellent thermal insulation and door sealing and electronic or mechanical control efficiently reduce power consumption. Gorenje A++ refrigerators verified by the Energy Saving Trust cost less than £3 to run every month.

(Based on NRC6192TXUK and NRK6192M. Figures are based on the EU Energy Label energy consumption. Average electricity price of 13.86p/kWh. Correct as of January 2016).

# FREESTANDING FRIDGE FREEZERS



**SUPERIOR line**



**ADVANCED line**

## ConvertActive

(available only in 1.85 m models)

	NoFrost cooling
<b>OPERATION</b>	
Mechanical	
Electronic	
Electronic LED display behind doors	
Electronic LED display on doors	●
<b>AdaptTech</b>	●
IonAir Dynamic Cooling	
IonAir Multiflow 360°	●
ECO mode	●
SlotIn	●
<b>EQUIPMENT</b>	
Simple Slide	●
PullOut shelves	●
CrispActive with VitaLight	●
FreshActive ↻	●
ZeroZone	●
MultiBox	●
XXL SpaceBox	●
Bottle rack	●
LED light	●
ALU profile shelves	●
ALU profile on drawers	●
ALU profile on door shelves	●
<b>HANDLE TYPE</b>	
Plastic	
Metal	●
<b>FREEZING SYSTEM</b>	
Fast Freeze	●
Xtreme Freeze	●

	NoFrost cooling
<b>OPERATION</b>	
Mechanical	
Electronic	
Electronic LED display behind doors	
Electronic LED display on doors	●
<b>AdaptTech</b>	●
IonAir Dynamic Cooling	
IonAir Multiflow 360°	●
ECO mode	
SlotIn	●
<b>EQUIPMENT</b>	
SimpleSlide	●
PullOut shelves	●
CrispZone with HumidityControl	●
FreshZone	●
ZeroZone	
MultiBox	●
XXL SpaceBox	●
Bottleholder	●
LED light	●
ALU profile shelves	●
ALU profile on drawers	●
ALU profile on door shelves	
<b>HANDLE TYPE</b>	
Plastic	
Metal	●
<b>FREEZING SYSTEM</b>	
FastFreeze	●
XtremeFreeze	

## FREESTANDING FRIDGE FREEZERS



**ESSENTIAL line**



**COLOUR edition - NRK6192M...**

OPERATION	FrostLess cooling	NoFrost cooling
Mechanical	●	
Electronic		●
Electronic LED display behind doors		
Electronic LED display on doors		
AdaptTech		
IonAir Dynamic Cooling		
IonAir Multiflow 360°		●
ECO mode		
SlotIn	●	●
<b>EQUIPMENT</b>		
SimpleSlide	●	●
PullOut shelves	●	●
CrispZone with HumidityControl	●	●
FreshZone	●	●
ZeroZone		
MultiBox		
XXL SpaceBox	●	●
Bottleholder	●	●
LED light	●	●
ALU profile shelves		
ALU profile on drawers		
ALU profile on door shelves		
<b>HANDLE TYPE</b>		
Plastic	●	
Metal		●
<b>FREEZING SYSTEM</b>		
FastFreeze		●
XtremeFreeze		

OPERATION	NoFrost cooling
Mechanical	
Electronic	
Electronic LED display behind doors	
Electronic LED display on doors	●
AdaptTech	●
IonAir Dynamic Cooling	
IonAir Multiflow 360°	●
ECO mode	
SlotIn	●
<b>EQUIPMENT</b>	
SimpleSlide	●
PullOut shelves	●
CrispZone with HumidityControl	●
FreshZone	●
ZeroZone	
MultiBox	●
XXL SpaceBox	●
Bottleholder	●
LED light	●
ALU profile shelves	●
ALU profile on drawers	●
ALU profile on door shelves	
<b>HANDLE TYPE</b>	
Plastic	
Metal	●
<b>FREEZING SYSTEM</b>	
FastFreeze	●
XtremeFreeze	

## FREESTANDING FRIDGE FREEZERS

## FREESTANDING REFRIGERATORS



COLOUR edition - RK 6192 E...



ESSENTIAL line

	FrostLess cooling
<b>OPERATION</b>	
Mechanical	●
Electronic	
Electronic LED display behind doors	
Electronic LED display on doors	
AdaptTech	
IonAir Dynamic Cooling	
ECO mode	
SlotIn	●
SuperCool	
<b>EQUIPMENT</b>	
Simple Slide	●
PullOut shelves	●
CrispZone with HumidityControl	●
CrispZone x 1	●
FreshZone x 2	
MultiBox	
Bottle rack	●
LED light	●
ALU profile shelves	●
ALU profile on drawers	
ALU profile on door shelves	
<b>HANDLE TYPE</b>	
Metal	●
Plastic	
<b>FREEZING SYSTEM</b>	
Fast Freeze	
Xtreme Freeze	

	Cooler
<b>OPERATION</b>	
Mechanical	●
Electronic	
Electronic LED display behind doors	
Electronic LED display on doors	
AdaptTech	
IonAir Dynamic Cooling	●
ECO mode	●
SlotIn	●
SuperCool	
<b>EQUIPMENT</b>	
Simple Slide	●
PullOut shelves	●
CrispZone with HumidityControl	●
CrispZone x 1	●
FreshZone x 2	●
MultiBox	
Bottle rack	●
LED light	●
ALU profile shelves	
ALU profile on drawers	
ALU profile on door shelves	
<b>HANDLE TYPE</b>	
Metal	●
Plastic	

## FREESTANDING FREEZERS



### ESSENTIAL line

	NoFrost Freezer
<b>OPERATION</b>	
Mechanical	
Electronic	●
Electronic LED display behind doors	
Electronic LED display on doors	
ECO mode	●
SlotIn	●
<b>EQUIPMENT</b>	
FastFreeze	●
Freezer door (flap) x 1	●
Upper freezer drawer x 2	●
SpaceBox x 3	●
Bottom freezer drawer x 1	●
LED light	●
MultiBox	
Ice rack	●
ALU profile on drawers	
<b>HANDLE TYPE</b>	
Metal	●
Plastic	



### NRC 6192 TXUK Superior Line

Freestanding Convert Active fridge freezer

### NRK 6202 MXUK Advanced Line

Freestanding NoFrost fridge freezer

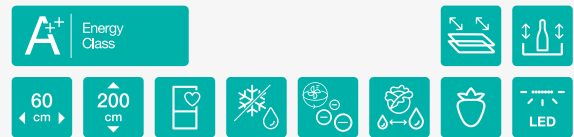
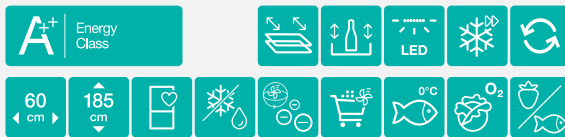

- Colour: Stainless steel
- Reversible door opening
- Door material: Steel sheet
- Climate class: SN, ST, N, T

- Colour: Stainless steel
- Reversible door opening
- Door material: Steel sheet
- Climate class: ST, N, T

<b>Efficiency</b>	<ul style="list-style-type: none"> <li>- 1 compressor</li> <li>- Total gross/net volume: 329 / 307 l</li> <li>- Capacity of cooling compartment: gross/net: 231 / 222 l</li> <li>- Capacity of freezer compartment: gross/net: 98 / 85 l</li> <li>- Freezing capacity in 24 hours: 12 kg / 24h</li> <li>- Power cut safe time: 18 h</li> </ul>	<ul style="list-style-type: none"> <li>- 1 compressor</li> <li>- Total gross/net volume: 363 / 339 l</li> <li>- Capacity of cooling compartment: gross/net: 265 / 254 l</li> <li>- Capacity of freezer compartment: gross/net: 98 / 85 l</li> <li>- Freezing capacity in 24 hours: 5 kg / 24h</li> <li>- Power cut safe time: 18 h</li> </ul>
<b>Control</b>	<ul style="list-style-type: none"> <li>- Electronic control</li> <li>- Type of display: LED</li> <li>- Sound alarm for open door</li> <li>- Sound and visual signal for high temperature in refrigerator: white signal</li> </ul>	<ul style="list-style-type: none"> <li>- Electronic control</li> <li>- Sound alarm for open door</li> <li>- Sound and visual signal for high temperature in refrigerator: white signal</li> </ul>
<b>Features</b>	<ul style="list-style-type: none"> <li>- ConvertActive: Converts freezer into refrigerator</li> <li>- IonAir: Ionizer in the fridge</li> <li>- AdaptTech cooling: Memorizing intelligent system</li> <li>- Multiflow 360 °: Multi 3D air blowing</li> <li>- Slot-in: possibility to put the appliance into the kitchen niche 60 cm</li> <li>- NoFrost Plus / SuperCool / FastFreeze</li> <li>- Saving programme EcoMode</li> <li>- XtremeFreeze: very intensive freezing in the upper freezer drawer</li> </ul>	<ul style="list-style-type: none"> <li>- IonAir: Ionizer in the fridge</li> <li>- AdaptTech cooling: Memorizing intelligent system</li> <li>- Multiflow 360 °: Multi 3D air blowing</li> <li>- Slot-in: possibility to put the appliance into the kitchen niche 60 cm</li> <li>- NoFrost Plus</li> </ul>
<b>Equipment of refrigerator</b>	<ul style="list-style-type: none"> <li>- Egg/Ice bin: 1 x 7</li> <li>- SimpleSLide height adjustable door shelves: 2</li> <li>- Type of interior light: LED stripe</li> <li>- 4 glass shelves</li> <li>- Bottle rack</li> <li>- Bottle shelf with fixed trap</li> <li>- MultiBox for butter and cheese</li> <li>- CrispActive drawer with VitaLight with HumidityControl</li> <li>- FreshActive drawer / ZeroZone drawer</li> </ul>	<ul style="list-style-type: none"> <li>- Egg/Ice bin: 1 x 7</li> <li>- SimpleSLide height adjustable door shelves: 3</li> <li>- Type of interior light: LED stripe</li> <li>- 5 glass shelves</li> <li>- Bottle rack</li> <li>- Bottle shelf with fixed trap</li> <li>- MultiBox for butter and cheese</li> <li>- FreshZone drawer</li> <li>- CrispZone drawer featuring HumidityControl</li> </ul>
<b>Equipment of freezer</b>	<ul style="list-style-type: none"> <li>- 1 XXL SpaceBox drawer for freezing</li> <li>- 2 drawers for freezing</li> </ul>	<ul style="list-style-type: none"> <li>- 1 XXL SpaceBox drawer for freezing</li> <li>- 2 drawers for freezing</li> </ul>
<b>Technical data</b>	<ul style="list-style-type: none"> <li>- Energy consumption kWh/24h: 0.643 kWh</li> <li>- Level of noise (max.): 42 dB(A)re 1 pW</li> <li>- Product dimensions (HxWxD): 185 × 60 × 64 cm</li> <li>- EAN code: 3838942092039</li> <li>- Product code: 527329</li> </ul>	<ul style="list-style-type: none"> <li>- Energy consumption kWh/24h: 0.671 kWh</li> <li>- Level of noise (max.): 42 dB(A)re 1 pW</li> <li>- Product dimensions (HxWxD): 200 × 60 × 64 cm</li> <li>- EAN code: 3838942084775</li> <li>- Product code: 519256</li> </ul>





**NRK 6191 GWUK**

- Colour: White
- EAN code: 3838942936401
- Product code: 427796

**RK 6202 EWUK**  
 Freestanding fridge freezer

Essential Line

**NRK 6191 GXUK**  
 Freestanding NoFrost fridge freezer

Essential Line

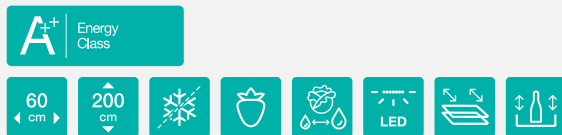

- Colour: White
- Reversible door opening
- Door material: Steel sheet
- Climate class: ST, N, T

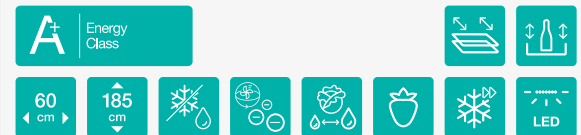

- Colour: Stainless steel
- Reversible door opening
- Door material: Steel sheet
- Climate class: ST, N, T

<b>Efficiency</b>	<ul style="list-style-type: none"> <li>- 1 compressor</li> <li>- Total gross/net volume: 354 / 352 l</li> <li>- Capacity of cooling compartment: gross/net: 258 / 257 l</li> <li>- Capacity of freezer compartment: gross/net: 96 / 95 l</li> <li>- Freezing capacity in 24 hours: 4.5 kg / 24h</li> <li>- Power cut safe time: 30 h</li> </ul>	<ul style="list-style-type: none"> <li>- 1 compressor</li> <li>- Total gross/net volume: 325 / 307 l</li> <li>- Capacity of cooling compartment: gross/net: 230 / 222 l</li> <li>- Capacity of freezer compartment: gross/net: 95 / 85 l</li> <li>- Freezing capacity in 24 hours: 5 kg / 24h</li> <li>- Power cut safe time: 21 h</li> </ul>
<b>Control</b>	- Mechanical control	- Electronic control
<b>Features</b>	<ul style="list-style-type: none"> <li>- Slot-in: possibility to put the appliance into the kitchen niche 60 cm</li> <li>- FrostLess: Less ice building in the freezer</li> </ul>	<ul style="list-style-type: none"> <li>- IonAir: Ionizer in the fridge</li> <li>- Multiflow 360 °: Multi 3D air blowing</li> <li>- Slot-in: possibility to put the appliance into the kitchen niche 60 cm</li> <li>- NoFrost Plus</li> <li>- FastFreeze</li> <li>- Saving programme EcoMode</li> </ul>
<b>Equipment of refrigerator</b>	<ul style="list-style-type: none"> <li>- Egg/Ice bin: Egg/Ice bin: 1 x 7</li> <li>- SimpleSLide height adjustable door shelves: 3</li> <li>- Type of interior light: LED stripe</li> <li>- 5 glass shelves</li> <li>- Bottle rack</li> <li>- Bottle shelf with fixed trap</li> <li>- FreshZone drawer</li> <li>- CrispZone drawer featuring HumidityControl</li> </ul>	<ul style="list-style-type: none"> <li>- Egg/Ice bin: 1 x 7</li> <li>- SimpleSLide height adjustable door shelves: 2</li> <li>- Type of interior light: LED</li> <li>- 4 glass shelves</li> <li>- Bottle rack</li> <li>- Bottle shelf with fixed trap</li> <li>- FreshZone drawer</li> <li>- CrispZone drawer featuring HumidityControl</li> </ul>
<b>Equipment of freezer</b>	<ul style="list-style-type: none"> <li>- 1 XXL SpaceBox drawer for freezing</li> <li>- 1 storage drawer</li> <li>- 1 drawer for freezing</li> </ul>	<ul style="list-style-type: none"> <li>- 1 XXL SpaceBox drawer for freezing</li> <li>- 2 drawers for freezing</li> </ul>
<b>Technical data</b>	<ul style="list-style-type: none"> <li>- Energy consumption kWh/24h: 0.659 kWh</li> <li>- Level of noise (max.): 40 dB(A)re 1 pW</li> <li>- Product dimensions (HxWxD): 200 × 60 × 64 cm</li> <li>- EAN code: 3838942083655</li> <li>- Product code: 519252</li> </ul>	<ul style="list-style-type: none"> <li>- Energy consumption kWh/24h: 0.819 kWh</li> <li>- Energy consumption kWh/year: 299 kWh</li> <li>- Level of noise (max.): 42 dB(A)re 1 pW</li> <li>- Product dimensions (HxWxD): 185 × 60 × 64 cm</li> <li>- EAN code: 3838942936418</li> <li>- Product code: 469425</li> </ul>



**NRK 6192 MBKUK** Colour Edition  
Freestanding NoFrost fridge freezer

**A+++** Energy Class
Reversible door opening
LED

60 cm
185 cm
MultiBox
IonAir
AdaptTech
NoFrost Plus

- Colour: Black
- Reversible door opening
- Door material: Steel sheet
- Climate class: SN, ST, N, T

<b>Efficiency</b>	<ul style="list-style-type: none"> <li>- 1 compressor</li> <li>- Total gross/net volume: 329 / 307 l</li> <li>- Capacity of cooling compartment: gross/net: 231 / 222 l</li> <li>- Capacity of freezer compartment: gross/net: 98 / 85 l</li> <li>- Freezing capacity in 24 hours: 5 kg / 24h</li> <li>- Power cut safe time: 18 h</li> </ul>
<b>Control</b>	<ul style="list-style-type: none"> <li>- Electronic control</li> <li>- Type of display: LED</li> <li>- Sound alarm for open door</li> <li>- Sound and visual signal for high temperature in refrigerator: white signal</li> </ul>
<b>Features</b>	<ul style="list-style-type: none"> <li>- IonAir with MultiFlow 360 °</li> <li>- AdaptTech cooling: Memorizing intelligent system</li> <li>- NoFrost Plus</li> </ul>
<b>Equipment of refrigerator</b>	<ul style="list-style-type: none"> <li>- Egg/Ice bin: Egg/Ice bin: 1 x 7</li> <li>- SimpleSlide height adjustable door shelves: 2</li> <li>- Type of interior light: LED strip</li> <li>- 4 glass shelves</li> <li>- Bottle rack</li> <li>- Bottle shelf with fixed trap</li> <li>- MultiBox for butter and cheese</li> <li>- CrispZone drawer featuring HumidityControl</li> <li>- FreshZone drawer</li> </ul>
<b>Equipment of freezer</b>	<ul style="list-style-type: none"> <li>- 1 XXL SpaceBox drawer</li> <li>- 2 drawers for freezing</li> </ul>
<b>Technical data</b>	<ul style="list-style-type: none"> <li>- Energy consumption kWh/24h: 0,643 kWh</li> <li>- Level of noise (max.): 42 dB(A)re 1 pW</li> <li>- Product dimensions (HxWxD): 185 × 60 × 64 cm</li> <li>- EAN code: 3838942111471</li> <li>- Product code: 547223</li> </ul>



**NRK 6192 MXUK**  
- Colour: Stainless steel  
- EAN code: 3838942084768  
- product code: 519255



**NRK 6192 MWUK**  
- Colour: White  
- EAN code: 3838942084751  
- Product code: 519254



**NRK 6192 MRDUK**  
- Colour: Fiery Red  
- EAN code: 3838942111464  
- Product code: 547214



**NRK 6192 MCUK**  
- Colour: Champagne  
- EAN code: 3838942111440  
- Product code: 547174



**NRK 6192 MRUK**  
- Colour: Bordeaux  
- EAN code: 3838942111457  
- Product code: 547175

5  
YEAR  
WARRANTY

## RK 6192 ECUK

### Freestanding fridge freezer

Colour Edition

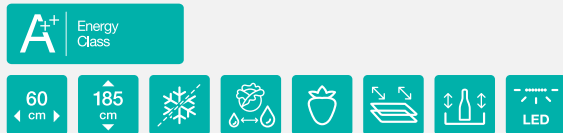

- Colour: Champagne
- Reversible door opening
- Door material: Steel sheet
- Climate class: SN, ST, N, T

<b>Efficiency</b>	<ul style="list-style-type: none"> <li>- 1 compressor</li> <li>- Total gross/net volume: 326 / 324 l</li> <li>- Capacity of cooling compartment: gross/net: 229 / 229 l</li> <li>- Capacity of freezer compartment: gross/net: 97 / 95 l</li> <li>- Freezing capacity in 24 hours: 4.5 kg / 24h</li> <li>- Power cut safe time: 30 h</li> </ul>
<b>Control</b>	<ul style="list-style-type: none"> <li>- Mechanical control</li> </ul>
<b>Features</b>	<ul style="list-style-type: none"> <li>- Slot-in: possibility to put the appliance into the kitchen niche 60 cm</li> <li>- FrostLess: Less ice building in the freezer</li> </ul>
<b>Equipment of refrigerator</b>	<ul style="list-style-type: none"> <li>- Egg/Ice bin: 1 x 7</li> <li>- SimpleSLide height adjustable door shelves: 2</li> <li>- Type of interior light: LED</li> <li>- 4 glass shelves</li> <li>- Bottle rack</li> <li>- Bottle shelf with fixed trap</li> <li>- FreshZone drawer</li> <li>- CrispZone drawer featuring HumidityControl</li> </ul>
<b>Equipment of freezer</b>	<ul style="list-style-type: none"> <li>- 1 XXL SpaceBox drawer for freezing</li> <li>- 1 storage drawer</li> <li>- 1 drawer for freezing</li> </ul>
<b>Technical data</b>	<ul style="list-style-type: none"> <li>- Energy consumption kWh/24h: 0.635 kWh</li> <li>- Energy consumption kWh/year: 232 kWh</li> <li>- Level of noise (max.): 40 dB(A)re 1 pW</li> <li>- Product dimensions (HxWxD): 185 x 60 x 64 cm</li> <li>- EAN code: 3838942257377</li> <li>- Product code: 453688</li> </ul>



### RK 6192 EOUK

- Colour: Juicy Orange
- EAN code: 3838942259081
- Product code: 453721



### RK 6192 ERDUK

- Colour: Fiery Red
- EAN code: 3838942258077
- Product code: 453689



### RK 6192 ERUK

- Colour: Bordeaux
- EAN code: 3838942259050
- Product code: 453690



### RK 6192 EBKUK

- Colour: Black
- EAN code: 3838942259098
- Product code: 453722

2  
YEAR  
WARRANTY2  
YEAR  
WARRANTY

### R 6192 FXUK

Freestanding refrigerator

Essential Line

### R 6192 FWUK

Freestanding refrigerator

Essential Line

A<sup>++</sup> Energy Class

LED



- Colour: Stainless steel
- Reversible door opening
- Door material: Steel sheet
- Climate class: SN, ST, N, T

A<sup>++</sup> Energy Class

LED



- Colour: White
- Reversible door opening
- Door material: Steel sheet
- Climate class: SN, ST, N, T

#### Efficiency

- 1 compressor
- Total gross/net volume: 370 / 368 l
- Capacity of cooling compartment: gross/net: 370 / 368 l

- 1 compressor
- Total gross/net volume: 370 / 368 l
- Capacity of cooling compartment: gross/net: 370 / 368 l

#### Control

- Mechanical control

- Mechanical control

#### Features

- CrispZone with HumidityControl: big vegetable drawer with humidity regulation
- CrispZone drawer with HumidityControl
- IonAir: Ionizer in the fridge
- Slot-in: possibility to put the appliance into the kitchen niche 60 cm
- DynamiCooling
- SuperCool

- CrispZone with HumidityControl: big vegetable drawer with humidity regulation
- CrispZone drawer with HumidityControl
- IonAir: Ionizer in the fridge
- Slot-in: possibility to put the appliance into the kitchen niche 60 cm
- DynamiCooling
- SuperCool

#### Equipment of refrigerator

- Egg/Ice bin: Egg/Ice bin: 1 x 7
- SimpleSLide height adjustable door shelves: 3
- Type of interior light: LED
- 7 glass shelves
- Bottle rack
- Bottle shelf without trap
- Bottle shelf with fixed trap
- FreshZone drawer

- Egg/Ice bin: Egg/Ice bin: 1 x 7
- SimpleSLide height adjustable door shelves: 3
- Type of interior light: LED
- 7 glass shelves
- Bottle rack
- Bottle shelf without trap
- Bottle shelf with fixed trap
- FreshZone drawer

#### Technical data

- Energy consumption kWh/24h: 0.312 kWh
- Energy consumption kWh/year: 114 kWh
- Level of noise (max.): 38 dB(A)re 1 pW
- Product dimensions (HxWxD): 185 × 60 × 64 cm
- EAN code: 3838942001543
- Product code: 469373

- Energy consumption kWh/24h: 0.312 kWh
- Energy consumption kWh/year: 114 kWh
- Level of noise (max.): 38 dB(A)re 1 pW
- Product dimensions (HxWxD): 185 × 60 × 64 cm
- EAN code: 3838942001536
- Product code: 469372



### FN 6192 CXUK

Freestanding NoFrost freezer

Essential Line

### FN 6192 CWUK

Freestanding NoFrost freezer

Essential Line

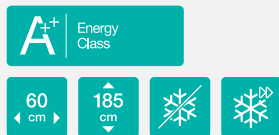

- Colour: Stainless steel
- Reversible door opening
- Climate class: SN, ST, N, T



- Colour: White
- Reversible door opening
- Climate class: SN, ST, N, T

<b>Efficiency</b>	<ul style="list-style-type: none"> <li>- 1 compressor</li> <li>- Total gross/net volume: 277 / 243 l</li> <li>- FastFreeze</li> <li>- Freezing capacity in 24 hours: 18 kg</li> <li>- Power cut safe time: 15 h</li> </ul>	<ul style="list-style-type: none"> <li>- 1 compressor</li> <li>- Total gross/net volume: 277 / 243 l</li> <li>- FastFreeze</li> <li>- Freezing capacity in 24 hours: 18 kg</li> <li>- Power cut safe time: 15 h</li> </ul>
<b>Control</b>	- Electronic control	- Electronic control
<b>Features</b>	<ul style="list-style-type: none"> <li>- Automatic defrost freezer</li> <li>- NoFrost</li> </ul>	<ul style="list-style-type: none"> <li>- Automatic defrost freezer</li> <li>- NoFrost</li> </ul>
<b>Equipment of freezer</b>	<ul style="list-style-type: none"> <li>- Illuminated interior of freezer compartment: LED light</li> <li>- Storage compartments with door for frozen food: 1</li> <li>- 5 storage drawers for frozen food</li> <li>- Drawers for freezing: 1</li> </ul>	<ul style="list-style-type: none"> <li>- Illuminated interior of freezer compartment: LED light</li> <li>- Storage compartments with door for frozen food: 1</li> <li>- 5 storage drawers for frozen food</li> <li>- Drawers for freezing: 1</li> </ul>
<b>Technical data</b>	<ul style="list-style-type: none"> <li>- Energy consumption kWh/24h: 0.649 kWh</li> <li>- Energy consumption kWh/year: 237 kWh</li> <li>- Level of noise (max.): 42 dB(A)re 1 pW</li> <li>- Product dimensions (HxWxD): 185 × 60 × 64 cm</li> <li>- EAN code: 3838942001529</li> <li>- Product code: 469371</li> </ul>	<ul style="list-style-type: none"> <li>- Energy consumption kWh/24h: 0.649 kWh</li> <li>- Energy consumption kWh/year: 237 kWh</li> <li>- Level of noise (max.): 42 dB(A)re 1 pW</li> <li>- Product dimensions (HxWxD): 185 × 60 × 64 cm</li> <li>- EAN code: 3838942000911</li> <li>- Product code: 469330</li> </ul>





# A WASHER WITH A GENTLE HEART

## Washing machines

Gorenje washing machines are a reliable partner in the daily care of your laundry. It understands the limited amount of time and patience for every day mundane tasks. Therefore, it offers programmes that are a perfect fit of different lifestyles and offer every user the functions they desire. It can wash quickly; it can wash environmentally friendly. It can be silent; they can be meticulously thorough. Regardless of the mode you choose, your laundry will always be washed gently and with care. The fabric will remain fresh and flexible, and the colours will retain the right hue.

# SensoCare

## Perfection in washing

SensoCare technology makes sure every type of fabric is washed in the best possible way. It always delivers the optimum combination of temperature and amount of water, time, and spin speed. If, however, your clothes need a very special care, the cotton and synthetic fibre programmes can be tweaked with

extra modes and functions. NormalCare selects the optimum combination of all four parameters for each load of laundry; TimeCare reduces the washing time; AllergyCare uses more water and extra rinse cycles; and EcoCare is the most energy-efficient washing mode.



 **TimeCare**  
40% quicker wash

Intensive and quicker wash for less soiled laundry and smaller loads.



 **EcoCare**  
60% energy savings

The wash is somewhat longer, but it uses less water and power.



 **AllergyCare**  
Efficient rinse

Additional level of water and thorough rinse are more efficient in removing the traces of detergent and thereby the allergens that could cause an unpleasant sensation on the skin.



# SpaDrum

## Total laundry care

The SensoCare washing machine drum is made from the best quality stainless steel with exceptionally smooth surface. Therefore, the laundry is thoroughly washed, rinsed, and spun without any damage.



### Perforation

Water gently spraying into the drum

Small holes with a diameter of no more than 3 millimetres treat your laundry especially gently. In addition to effective washing, spinning, and rinsing, they also prevent any damage to your laundry. Moreover, the size, shape and pattern of drum perforation reduce the consumption of power and water.



### 3D ribs

Gentle waving of the laundry

First, the wavy ribs gently push the laundry towards the rear end of the drum; then, they lift it toward to top. This improves the distribution of laundry within the drum, and delicately massages the fabric. Additional water is sprayed from the openings in the rib surface for better soaking.



### Tilted 4D door

Always on the right path

Improved patented glass washing machine door is designed for active 4D motion of the laundry towards the central part of the drum where it receives the best treatment and maximum protection. Laundry is better washed and less wrinkled, appliance quieter with extended lifetime.



## UltraWhite

White that will never turn grey

Synthetic fibres, silk, and nylon are easily damaged in machine washing. Therefore, a special programme has been developed to wash at lower temperatures and preserve the quality of your delicates. Gentle tumbling with a larger amount of water delivers perfect whiteness at no more than 30 °C. Use of specialized detergents is recommended for extra freshness.



## PerfectBlack

There is only one black

A special washing programme for all types of black fabric is highly efficient with gentle tumbling at no more than 30 °C. This does away with the need for intensive tumbling and use of aggressive detergents that make the laundry fade to grey. Specialized detergents are recommended for delicate black laundry.



## Anti-allergy programmes

For extra protection of delicate skin of babies and adults

Anti-allergy Cotton, Baby, Anti-Mites programmes use higher temperature, more water, and extra rinsing. As a result, the detergent is dissolved more efficiently and the laundry is very thoroughly rinsed. Washing powder, allergens, and mites that could cause an unpleasant sensation on sensitive or particularly delicate baby skin will be eliminated from your clothing, bedding, and larger clothing items.



## NightWash

The laundry can also be easily and silently washed at night. The drum spins more slowly and gently, but this is compensated with a somewhat longer wash that leaves the laundry perfectly clean.



## BioWash

A perfect solution for all who use organic washing agents such as laundry balls or soap nuts. The combination of a larger amount of water, temperatures of up to 90 °C, and fast tumbling allows optimum use of the organic washing agents and clean laundry.



## MyFavourite

Your washing machine can simply memorize your favourite or most frequently used programmes to make them always available for instant selection. It can also memorize all extra settings such as adjusted washing temperature, spinning speed, or a pre-wash.



## SportWash

Gentle tumbling of the laundry in a large amount of water at 30 to 40 °C is ideal for washing synthetic fibres. Thus, your sportswear will always be fresh and pleasantly smelling, ready for new endeavours.



## HandWash + Wool

This programme takes care of woollen, silk, or lace garments as if they were washed by a pair of caring hands. The shape and quality will be maintained, and the stains and dirt will be removed at temperatures as low as 30 to 40 °C.



## QuickWash 17'

Less soiled laundry can be easily refreshed in 17 minutes at a temperature of 30 °C. Thus, your next outfit will always be ready.

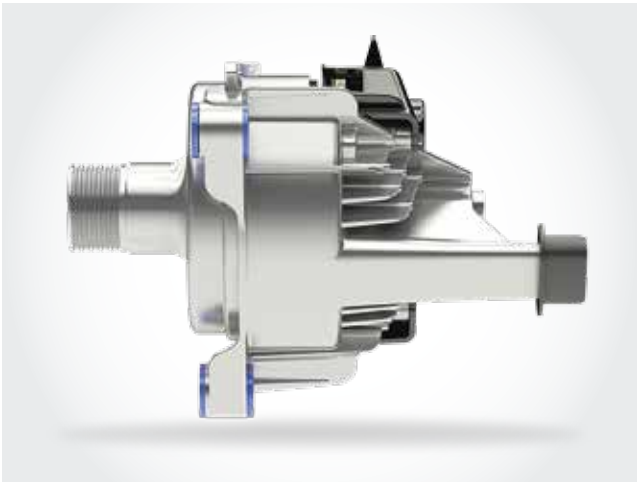

### InverterPowerDrive

Remarkable power, high efficiency

The powerful motor is brushless, which eliminates and mechanical tension, friction, or wear. The results are better, power savings are higher, and the washing process is notably quieter. Moreover, appliance useful life is longer, too.



### TotalWeightControl

Superior washing results regardless of the amount of laundry

The sensor adjusts all washing parameters to the amount of laundry in the drum. This leads to optimum use of water and power, shorter wash, and considerably quieter operation. A full basket of laundry, no matter how large, will be clean and pleasantly smelling.



### StainExpert

Expert in stains

Effective removal of stains no longer requires high temperature or additional treatment of clothing before the wash. The perfect combination of temperature, time, and water will automatically remove four types of stubborn stains: fruit (oranges, tomato sauce); organic stains (fat, butter, eggs, grass); wine (dark fruit juices, ink); and coffee (tea, yoghurt, pasta, make-up). The StainExpert function is available in the Superior washing machines.



### DuraHeat

Safe and durable

The redesigned and improved heater includes an overheating protection system. This extends its useful life and makes washing machine operation safer.

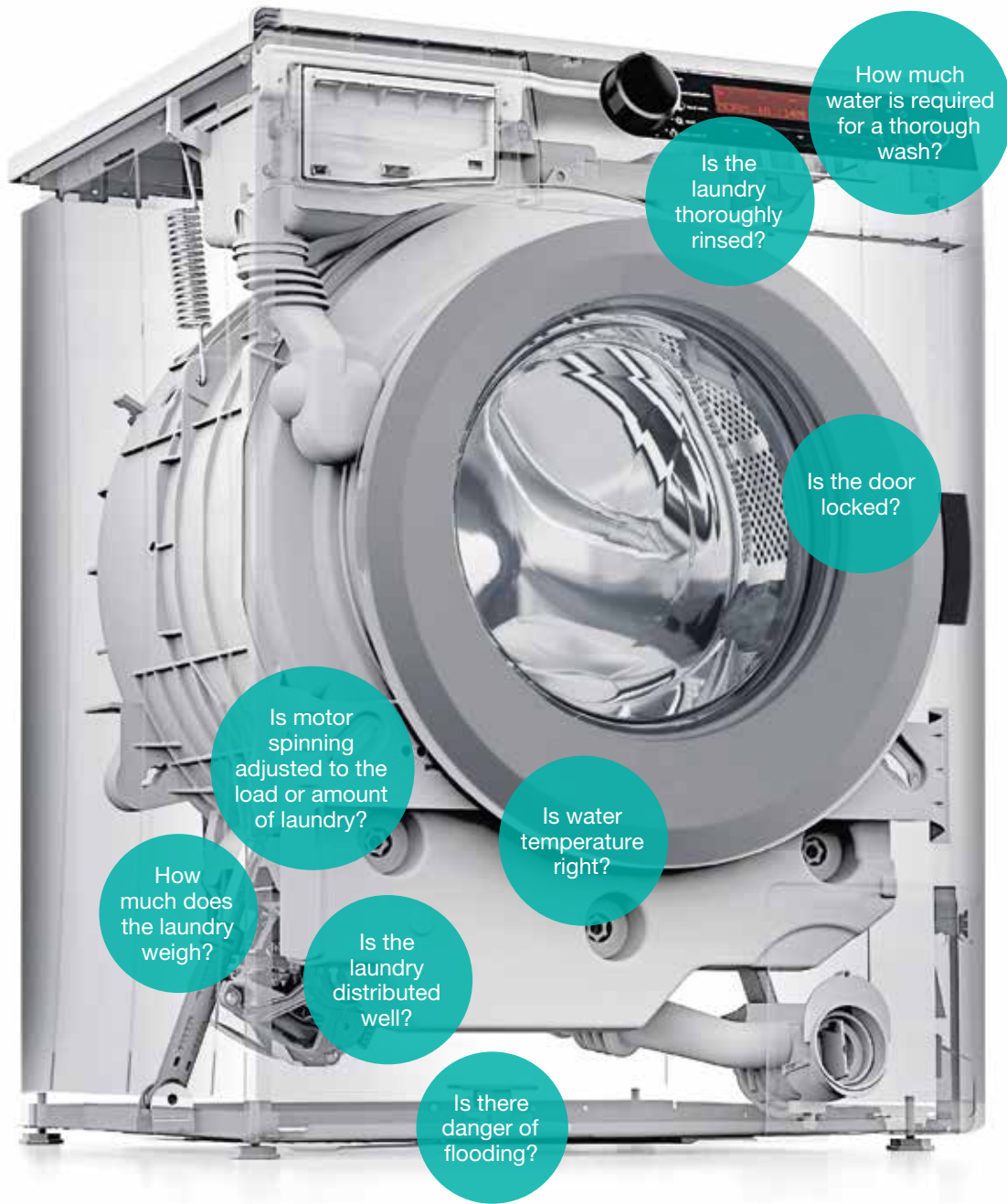

## Sensor IQ

Smart wash

The sensor system controls washing process and makes sure it is perfect. Smart technology adjusts the amount of water and washing time to the selected program, and type and weight of the laundry. The results is excellently washed laundry and lower use of power, water, and time.



## Friendly design

Gorenje washing machines are designed to be functional and ergonomic, which makes their use inspiringly simple. The control panel is tilted by 20° and the door opening has a large 34 cm diameter for easier filling and emptying of the washing machine. Filters and detergent dispenser are also easy to clean.



## SteriTub

This program makes sure the washing machine interior stays perfectly clean and sterile, allowing a pleasant smell of the laundry. Washing with washing powder at lower temperatures may lead to ideal conditions for development of bacteria which in turn could cause a foul smell of your laundry. The SteriTub works with the drum empty and eliminates and bacteria from the machine interior.



## A+++ -20%

All washing machines are highly energy-efficient. Those ranking in the A+++ -20% energy class use 50% less power than the A-class appliances.



## ChildLock

During the wash, the door stays locked, preventing even the most inquisitive child from opening it. For added protection, the control panel can be locked by pressing a special combination of keys, making it impossible to inadvertently change the settings.



## AquaStop

The safety system automatically shuts off the water supply to the hose and the machine in case of a leak to prevent flooding. The pump automatically pumps out the remaining water from the drum into the discharge hose. Thus, the washing machine can be left to operate unsupervised, without any fear of flooding. High-end models feature a special sensor installed at the bottom of the washing machine. In case of a leak, the sensor will immediately cut off the supply of water into the appliance.



## Zinc-coated housing

Gorenje washing machines are coated with an environmentally friendly protective layer that fends off rust and extends the useful life of the appliance.



## SuperSilent

Quality drive and insulation allows the SensoCare washing machines to operate quietly. Even during the hardest spin, it will not be louder than a normal conversation. Top models excel with extra silent operation.



SUPERIOR line



ESSENTIAL line

		Standard 60 cm
CAPACITY	6kg	
	7kg	
	8kg	
	9kg	●
SPIN SPEED	600	
	800	
	1000	
	1200	
	1400	
	1600	●
ENERGY CLASS	A++	
	A+++	
	A+++ -10%	
	A+++ -20%	●
DISPLAY	LED diodes	
	LED	
	LCD	
	Large LCD	●
4 WASHING MODES	(NormalCare, EcoCare, AllergyCare, TimeCare)	●
SPECIAL PROGRAMMES	UltraWhite	●
	PerfectBlack	●
	Anti-allergy programmes	
	MyFavorite	●
	BioWash	●
	NightWash	●
	StainExpert	●
NO. OF SENSORS	6	
	7	
	8	●
SOAKING SYSTEM	Showering	
	Showering+ Jet (QuickWet)	●
DRUM CAPACITY	42l	
	54l	
	64l	●
TUB	Carbotech	
	Fibertech	●
MOTOR	Standard collector motor	
	InverterPowerDrive	●
SAFETY	AquaStop	
	Total AquaStop	●

		Slim 45 cm	Standard 60 cm
CAPACITY	6kg	●	
	7kg		●
	8kg		●
	9kg		●
SPIN SPEED	600		
	800		
	1000		
	1200	●	
	1400		●
	1600		●
ENERGY CLASS	A++		
	A+++	●	●
	A+++ -10%		●
	A+++ -20%		●
DISPLAY	LED diodes		
	LED	●	●
	LCD		
	Large LCD		
4 WASHING MODES	(NormalCare, EcoCare, AllergyCare, TimeCare)	●	●
SPECIAL PROGRAMMES	UltraWhite	●	●
	PerfectBlack	●	●
	Anti-allergy programmes		
	MyFavorite	●	●
	BioWash	●	●
	NightWash	●	●
	StainExpert		
NO. OF SENSORS	6		
	7	●	●
	8		
SOAKING SYSTEM	Showering	●	●
	Showering+ Jet (QuickWet)		●
DRUM CAPACITY	42l	●	
	54l		●
	64l		●
TUB	Carbotech	●	●
	Fibertech		●
MOTOR	Standard collector motor	●	●
	InverterPowerDrive		●
SAFETY	AquaStop		●
	Total AquaStop		



## COLOUR edition

		Standard 60 cm
<b>CAPACITY</b>	6kg	
	7kg	
	8kg	●
	9kg	
<b>SPIN SPEED</b>	600	
	800	
	1000	
	1200	
	1400	●
	1600	
<b>ENERGY CLASS</b>	A++	
	A+++	●
	A+++ -10%	
	A+++ -20%	
<b>DISPLAY</b>	LED diodes	
	LED	●
	LCD	
	Large LCD	
<b>4 WASHING MODES</b>	(NormalCare, EcoCare, AllergyCare, TimeCare)	●
<b>SPECIAL PROGRAMMES</b>	UltraWhite	●
	PerfectBlack	●
	Anti-allergy programmes	
	MyFavorite	●
	BioWash	●
	NightWash	●
	StainExpert	
<b>NO. OF SENSORS</b>	6	
	7	●
	8	
<b>SOAKING SYSTEM</b>	Showering	●
	Showering+ Jet (QuickWet)	
<b>DRUM CAPACITY</b>	42l	
	54l	
	64l	●
<b>TUB</b>	Carbotech	
	Fibertech	●
<b>MOTOR</b>	Standard collector motor	●
	InverterPowerDrive	
<b>SAFETY</b>	AquaStop	●
	Total AquaStop	



**W 98F65 E/IUK**  
Washing machine

Superior Line



- Colour: White



**W 95F64 P/IUK**  
Washing machine

Essential Line



- Colour: White

<b>Efficiency</b>	<ul style="list-style-type: none"> <li>- Inverter PowerDrive</li> <li>- SensoCARE</li> <li>- StainExpert</li> <li>- Special drum construction SpaDrum</li> <li>- Spin speed: 1600 rpm</li> <li>- Washer load: 1-9 kg</li> <li>- Drum volume: 64 l</li> <li>- Drum illumination with LED light</li> </ul>	<ul style="list-style-type: none"> <li>- Inverter PowerDrive</li> <li>- SensoCARE</li> <li>- Special drum construction SpaDrum</li> <li>- Spin speed: 1600 rpm</li> <li>- Washer load: 1-9 kg</li> <li>- Drum volume: 64 l</li> </ul>
<b>Control</b>	<ul style="list-style-type: none"> <li>- Type of display: LCD</li> <li>- TimeComfort</li> <li>- Presetting time delay of start</li> <li>- Preset washing EndTime / Adjustable spin speed / Temperature setting / Cold wash: Button / Personal settings for all programmes</li> </ul>	<ul style="list-style-type: none"> <li>- Type of display: LED</li> <li>- Presetting time delay of start</li> <li>- Adjustable spin speed</li> <li>- Temperature setting / Cold wash: Button / Personal settings for all programmes</li> </ul>
<b>Programmes</b>	<ul style="list-style-type: none"> <li>- 31 programmes</li> <li>- Cotton, Wool, QuickWash, Mix synthetics, HandWash</li> <li>- Prewash</li> <li>- Special programs: BioWash, MyFavorite, NightWash, PerfectBlack, UltraWhite, SportWash</li> <li>- Ability to create own programmes: MyFavorite</li> </ul>	<ul style="list-style-type: none"> <li>- 23 programmes</li> <li>- Cotton, Wool, QuickWash, Mix synthetics, HandWash</li> <li>- Prewash</li> <li>- Special programs: BioWash, MyFavorite, NightWash, PerfectBlack, UltraWhite, SportWash</li> <li>- Ability to create own programmes: MyFavorite</li> </ul>
<b>Features</b>	<ul style="list-style-type: none"> <li>- Audio signal SoftSound</li> <li>- Self cleaning program SterilTub</li> <li>- Pump STOP</li> <li>- Cold &amp; hot water connection</li> </ul>	<ul style="list-style-type: none"> <li>- Audio signal SoftSound</li> <li>- Self cleaning program SterilTub</li> <li>- Pump STOP</li> <li>- Cold water connection</li> </ul>
<b>SensorIQ technology</b>	<ul style="list-style-type: none"> <li>- Automatic recognition of laundry weight TotalWeight</li> <li>- QuickWet</li> <li>- ECOSystem</li> </ul>	<ul style="list-style-type: none"> <li>- Automatic recognition of laundry weight TotalWeight</li> <li>- QuickWet</li> <li>- ECOSystem</li> </ul>
<b>Safety and durability</b>	<ul style="list-style-type: none"> <li>- Durable heater DuraHeat</li> <li>- Total Aqua STOP</li> <li>- Overflow protection</li> <li>- Child protection (CDP) / Stability Control (SCS)</li> <li>- FiberTech</li> </ul>	<ul style="list-style-type: none"> <li>- Durable heater DuraHeat</li> <li>- Partial AquaStop</li> <li>- Overflow protection</li> <li>- Child protection (CDP) / Stability Control (SCS)</li> <li>- FiberTech</li> </ul>
<b>Technical data</b>	<ul style="list-style-type: none"> <li>- Energy consumption kWh/year: 170 kWh</li> <li>- Annual water consumption: 10654 l</li> <li>- Level of noise (max.): 74 dB(A)re 1 pW</li> <li>- Product dimensions (HxWxD): 85 × 60 × 60 cm</li> <li>- EAN code 3838942081286</li> <li>- Product code: 517217</li> </ul>	<ul style="list-style-type: none"> <li>- Energy consumption kWh/year: 187 kWh</li> <li>- Annual water consumption: 10780 l</li> <li>- Level of noise (max.): 76 dB(A)re 1 pW</li> <li>- Product dimensions (HxWxD): 85 × 60 × 60 cm</li> <li>- EAN code: 3838942081262</li> <li>- Product code: 517216</li> </ul>







### W 85F44 P/IUK

Washing machine

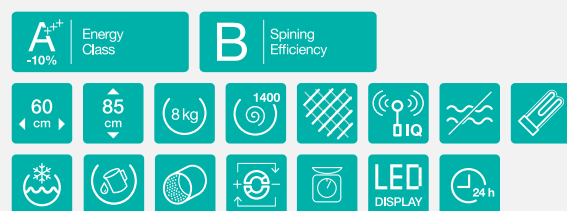
Essential Line



- Colour: White

### W 8543 C

Washing machine

Essential Line



- Colour: White

<b>Efficiency</b>	<ul style="list-style-type: none"> <li>- Inverter PowerDrive</li> <li>- SensoCARE</li> <li>- Special drum construction SpaDrum</li> <li>- Spin speed: 1400 rpm</li> <li>- Washer load: 1-8 kg</li> <li>- Drum volume: 64 l</li> </ul>	<ul style="list-style-type: none"> <li>- Standard collector motor</li> <li>- SensoCARE</li> <li>- Special drum construction SpaDrum</li> <li>- Spin speed: 1400 rpm</li> <li>- Washer load: 1-8 kg</li> <li>- Drum volume: 64 l</li> </ul>
<b>Control</b>	<ul style="list-style-type: none"> <li>- Type of display: LED</li> <li>- Presetting time delay of start</li> <li>- Adjustable spin speed</li> <li>- Temperature setting / Cold wash: Button / Personal settings for all programmes</li> </ul>	<ul style="list-style-type: none"> <li>- Type of display: LED</li> <li>- Presetting time delay of start</li> <li>- Adjustable spin speed</li> <li>- Temperature setting</li> <li>- Cold wash: Button</li> <li>- Personal settings for all programmes</li> </ul>
<b>Programmes</b>	<ul style="list-style-type: none"> <li>- 23 programmes</li> <li>- Cotton, Wool, QuickWash, Mix synthetics, HandWash</li> <li>- Prewash</li> <li>- Special programs: BioWash, MyFavorite, NightWash, PerfectBlack, UltraWhite, SportWash</li> <li>- Ability to create own programmes: MyFavorite</li> </ul>	<ul style="list-style-type: none"> <li>- 23 programmes</li> <li>- Wool, Hand wash, Mix, Cotton, Quick programme, Synthetics</li> <li>- Special programs: BioWash, UltraWhite, PerfectBlack, NightWash, Sport, Eco programme, MyFavorite</li> </ul>
<b>Features</b>	<ul style="list-style-type: none"> <li>- Audio signal SoftSound</li> <li>- Self cleaning program SteriTub</li> <li>- Pump STOP</li> <li>- Cold water connection</li> </ul>	<ul style="list-style-type: none"> <li>- Audio signal SoftSound</li> <li>- Self cleaning program SteriTub</li> <li>- Pump STOP</li> <li>- Cold water connection</li> </ul>
<b>SensorIQ technology</b>	<ul style="list-style-type: none"> <li>- Automatic recognition of laundry weight TotalWeight</li> <li>- ECOSystem</li> </ul>	<ul style="list-style-type: none"> <li>- Automatic recognition of laundry weight TotalWeight</li> <li>- ECOSystem</li> </ul>
<b>Safety and durability</b>	<ul style="list-style-type: none"> <li>- Durable heater DuraHeat</li> <li>- Partial AquaStop</li> <li>- Overflow protection</li> <li>- Child protection (CDP) / Stability Control (SCS)</li> <li>- FiberTech</li> </ul>	<ul style="list-style-type: none"> <li>- Durable heater DuraHeat</li> <li>- Overflow protection</li> <li>- Child protection (CDP)</li> <li>- Stability Control (SCS)</li> <li>- FiberTech</li> </ul>
<b>Technical data</b>	<ul style="list-style-type: none"> <li>- Energy consumption kWh/year: 166 kWh</li> <li>- Annual water consumption: 10309 l</li> <li>- Level of noise (max.): 74 dB(A)re 1 pW</li> <li>- Product dimensions (HxWxD): 85 × 60 × 60 cm</li> <li>- EAN code: 3838942081279</li> <li>- Product code: 517215</li> </ul>	<ul style="list-style-type: none"> <li>- Energy consumption kWh/year: 192 kWh</li> <li>- Annual water consumption: 10340 l</li> <li>- Level of noise (max.): 74 dB(A)re 1 pW</li> <li>- Product dimensions (HxWxD): 85 × 60 × 60 cm</li> <li>- EAN code: 3838942269059</li> <li>- Product code: 454594</li> </ul>



**W 7543 LC**  
Washing machine

Essential Line

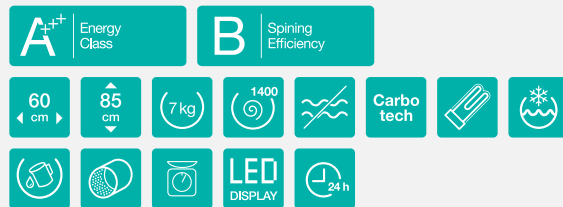

- Colour: White



**W 6523/SC**  
Washing machine

Essential Line

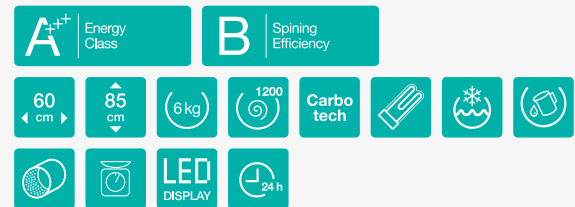

- Colour: White

<b>Efficiency</b>	<ul style="list-style-type: none"> <li>- Standard collector motor</li> <li>- SensoCARE</li> <li>- Special drum construction SpaDrum</li> <li>- Spin speed: 1400 rpm</li> <li>- Washer load: 1-7 kg</li> <li>- Drum volume: 54 l</li> </ul>	<ul style="list-style-type: none"> <li>- Standard collector motor</li> <li>- SensoCARE</li> <li>- Special drum construction SpaDrum</li> <li>- Spin speed: 1200 rpm</li> <li>- Washer load: 1-6 kg</li> <li>- Drum volume: 42 l</li> </ul>
<b>Control</b>	<ul style="list-style-type: none"> <li>- Type of display: LED</li> <li>- Pressetting time delay of start</li> <li>- Adjustable spin speed</li> <li>- Temperature setting</li> <li>- Cold wash: Button</li> <li>- Personal settings for all programmes</li> </ul>	<ul style="list-style-type: none"> <li>- Type of display: LED</li> <li>- Pressetting time delay of start</li> <li>- Adjustable spin speed</li> <li>- Temperature setting</li> <li>- Cold wash: Button</li> <li>- Personal settings for all programmes</li> </ul>
<b>Programmes</b>	<ul style="list-style-type: none"> <li>- 23 programmes</li> <li>- Wool, Hand wash, Mix, Cotton, Quick programme, Synthetics</li> <li>- Special programs: BioWash, UltraWhite, PerfectBlack, NightWash, Sport, Eco programme, MyFavorite</li> </ul>	<ul style="list-style-type: none"> <li>- 23 programmes</li> <li>- Wool, Hand wash, Mix, Cotton, Quick programme, Synthetics</li> <li>- Special programs: BioWash, UltraWhite, PerfectBlack, NightWash, Sport, Eco programme, MyFavorite</li> </ul>
<b>Features</b>	<ul style="list-style-type: none"> <li>- Audio signal SoftSound</li> <li>- Self cleaning program SterilTub</li> <li>- Pump STOP</li> <li>- Cold water connection</li> </ul>	<ul style="list-style-type: none"> <li>- Audio signal SoftSound</li> <li>- Self cleaning program SterilTub</li> <li>- Pump STOP</li> <li>- Cold water connection</li> <li>- Slim Depth</li> </ul>
<b>SensorIQ technology</b>	<ul style="list-style-type: none"> <li>- Automatic recognition of laundry weight TotalWeight</li> <li>- ECOSystem</li> </ul>	<ul style="list-style-type: none"> <li>- Automatic recognition of laundry weight TotalWeight</li> <li>- ECOSystem</li> </ul>
<b>Safety and durability</b>	<ul style="list-style-type: none"> <li>- Durable heater DuraHeat</li> <li>- Partial AquaStop / Overflow protection</li> <li>- Child protection (CDP) / Stability Control (SCS)</li> <li>- Carbotech tub</li> </ul>	<ul style="list-style-type: none"> <li>- Durable heater DuraHeat</li> <li>- Overflow protection</li> <li>- Child protection (CDP) / Stability Control (SCS)</li> <li>- Carbotech tub</li> </ul>
<b>Technical data</b>	<ul style="list-style-type: none"> <li>- Energy consumption kWh/year: 166 kWh</li> <li>- Annual water consumption: 9586 l</li> <li>- Level of noise (max.): 73 dB(A)re 1 pW</li> <li>- Product dimensions (HxWxD): 85 × 60 × 60 cm</li> <li>- EAN code: 3838942919879</li> <li>- Product code: 417994</li> </ul>	<ul style="list-style-type: none"> <li>- Energy consumption kWh/year: 153 kWh</li> <li>- Annual water consumption: 9209 l</li> <li>- Level of noise (max.): 70 dB(A)re 1 pW</li> <li>- Product dimensions (HxWxD): 85 × 60 × 44 cm</li> <li>- EAN code: 3838942948749</li> <li>- Product code: 432150</li> </ul>

5  
YEAR  
WARRANTY



**W 8543 LB** Colour Edition  
Washing machine

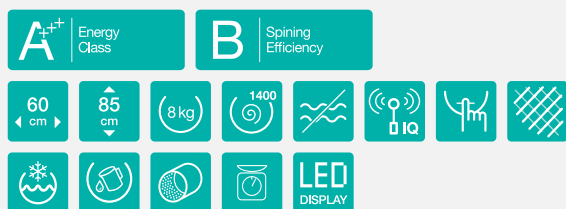

- Colour: Black

<b>Efficiency</b>	<ul style="list-style-type: none"> <li>- Standard collector motor</li> <li>- SensoCARE</li> <li>- Special drum construction SpaDrum</li> <li>- Spin speed: 1400 rpm</li> <li>- Washer load: 1-8 kg</li> <li>- Drum volume: 64 l</li> </ul>
<b>Control</b>	<ul style="list-style-type: none"> <li>- Type of display: LED</li> <li>- Adjustable spin speed</li> <li>- Temperature setting</li> <li>- Cold wash: Button</li> <li>- Personal settings for all programmes</li> </ul>
<b>Programmes</b>	<ul style="list-style-type: none"> <li>- 23 programmes</li> <li>- Wool, Hand wash, Mix, Cotton, Quick programme, Synthetics</li> <li>- Prewash</li> <li>- Special programs: Allergycotton, Baby, Anti mites, Silent washing, Active, PerfectBlack / Ability to create own programmes: MyFavorite</li> </ul>
<b>Features</b>	<ul style="list-style-type: none"> <li>- Audio signal SoftSound</li> <li>- Self cleaning program SterilTub</li> <li>- Pump STOP</li> <li>- Cold water connection</li> </ul>
<b>SensorIQ technology</b>	<ul style="list-style-type: none"> <li>- Automatic recognition of laundry weight TotalWeight</li> <li>- ECOSystem</li> </ul>
<b>Safety and durability</b>	<ul style="list-style-type: none"> <li>- Partial Aqua Stop</li> <li>- Overflow protection</li> <li>- Child protection (CDP)</li> <li>- Stability Control (SCS)</li> <li>- FiberTech</li> </ul>
<b>Technical data</b>	<ul style="list-style-type: none"> <li>- Energy consumption kWh/year: 192 kWh</li> <li>- Annual water consumption: 10340 l</li> <li>- Level of noise (max.): 73 dB(A)re 1 pW</li> <li>- Product dimensions (HxWxD): 85 × 60 × 60 cm</li> <li>- EAN code: 3838942608292</li> <li>- Product code: 460779</li> </ul>



**W 8543 LA**  
 - Colour: Silver  
 - EAN code: 3838942608742  
 - Product code: 460778



**W 8543 LR**  
 - Colour: Fiery Red  
 - EAN code: 3838942609282  
 - Product code: 460776



**W 8543 LO**  
 - Colour: Juicy Orange  
 - EAN code: 3838942606847  
 - Product code: 460780





# ALWAYS NICELY DRY

## Tumble dryers

A Gorenje laundry dryer can easily become your best friend, especially when you are in a hurry. Its drum delivers the power of negative ions that make the laundry extra soft, pleasantly smelling, and free of allergens. It also dries the laundry in a way that makes ironing very easy and often not required at all. In a Gorenje dryer, the fabric keeps its shape, flexibility, and stiffness. Dryer interior is large enough for large amounts of laundry. Models fitted with a heat pump, are also excitingly economical in terms of power consumption.

# SensoCare

## Sensationally soft laundry

The SensoCare technology makes sure that each type of fabric is dried in the best possible way. The combination of temperature, steam, drying time, and drum rotation afford drying

conditions tailored to your laundry. While NormalCare delivers improved drying programs for all types of laundry, GentleCare will provide a friendlier care for your delicates.



### IonTech

Fighting the allergies with ions

In SensoCare dryers, air full of negatively charged ions dries the laundry in a way that considerably reduces creasing of your clothes. The ionizer emits negative ions to effectively eliminate most allergens, residues of smoke and pollen, and the electrostatic charge accumulated during the drying process. As a result, the clothes have a better smell and they are easier to iron.



### SteamTech

Fewer creases, less ironing

Additional steam treatment at the end of the selected program will make sure your clothes are much smoother. The drum is filled with steam that penetrates every fibre for softer laundry that hardly requires any ironing.



### GentleCare

Gentle drying of delicate fabrics

Specialized care of the most delicate fabrics operates at a low temperature of 40 °C. A longer drying cycle is entirely safe and reliable as it protects your clothes from any deforming or damage.



## HeatPump with TwinAir Revolutionary drying efficiency

All heat pump dryers boast high energy efficiency. High end models rank in the A+++ energy class, saving 63% of energy compared to those in the A energy class. Gorenje A+++ class dryer with a capacity of 9 kg is unique in the market. Optimized heat pump in one of the largest drums in the world, with a

capacity of 120 litres, can easily deal with major amounts of laundry. This is also made possible by the broader air channels. It also dries more gently than conventional drying systems. The temperature in the dryer is at the ideal 50 °C to prevent from overdrying.



## TwinAir Evenly dried for simple ironing

Soft, evenly dried, less creased laundry that is easy to iron, straight from the dryer. This is made possible by the bi-directional air blowing system which adjusts the air blowing direction to the direction of drum rotation using a special flap on the fan.



## Sensor IQ

Sensor technology for safe operation

Smart sensor technology automatically controls the drying process according to the selected program, type of laundry, and desired dryness of laundry. Efficient sensor communication prevents any errors

and maintains the best possible laundry drying environment. The sensors also monitor all other parameters to reduce power consumption.



## InverterPowerDrive

Sensor technology for safe operation

Laundry dryer with an inverter motor can adjust the drum rotation speed for higher drying efficiency, better drying results, and softer laundry. The brushless motor is notably quieter, uses less power, and lasts longer.







## FiltrationSupreme

Gorenje has the most efficient filtering system in the world, providing 40% more efficient air filtering than conventional systems. It includes a special 3D filter installed before the condenser unit, a filter on the dryer door, and a filter in the drum. These filters catch even the tiniest bits of dust and lint from the clothes. After the drying cycle, the latter two filters are simply wiped.



## User-friendly condensate tank

The dryers condense all the moisture and drain it into a special tank. This does away with any worries regarding air evacuation. The light on the tank signals when the tank is full. The tank can be easily removed and emptied, and the water can be used elsewhere in your household.



## AutoDrain

Condensation dryer with the AutoDrain drain hose can be connected to your drain system to do away with the need for manual emptying of the condensate tank.



## Friendly design

Gorenje dryers have a clearly laid out control panel that is slightly tilted to allow a clearer view. They are designed for simple and pleasant use, featuring one of the largest door openings, simple opening system, and easily accessible filters and condensate tank.



## Top energy efficiency

A+++ is one of the best energy ratings you can get for a tumble dryer. Upgrading to a A+++ tumble dryer could save you £28 every year when compared to a C-rated model of the same size, that's enough money saved to pay for your daily newspaper for 40 days!

(This is for the Gorenje D98F66EUK. Figures based on the EU Energy Label energy consumption. This assumes 160 loads per year. Average electricity price of 13.86p/kWh. Lifetime assumed to be 13 years - source: DEFRA/DECC Powering the Nation 2. Assumed retail cost of £659. Correct as of January 2016).





SUPERIOR line



ESSENTIAL line

CAPACITY	6 kg	
	7 kg	
	8 kg	
	9 kg	●
ENERGY CLASS	C	
	B	
	A+	
	A++	
	A+++	●
DISPLAY	LED diodes	
	LED	
	LCD	●
OPERATION	Vents	
	Condenser	
	Condenser with HeatPump	●
CONTROL	Sensors	●
NO. OF PROGRAMS	15	
	27	●
DRUM CAPACITY	117 l	
	120 l	●
DRYING MODES	NormalCare	●
	GentleCare	●
DRUM	Drum illumination	●
	IonTech	●
	SteamTech	●
	TwinAir	●

CAPACITY	6 kg	
	7 kg	●
	8 kg	●
	9 kg	●
ENERGY CLASS	C	
	B	●
	A+	
	A++	●
	A+++	
DISPLAY	LED diodes	
	LED	●
	LCD	
OPERATION	Vents	
	Condenser	●
	Condenser with HeatPump	●
CONTROL	Sensors	●
NO. OF PROGRAMS	15	●
	27	
DRUM CAPACITY	117 l	●
	120 l	●
DRYING MODES	NormalCare	●
	GentleCare	
DRUM	Drum illumination	●
	IonTech	
	SteamTech	●
	TwinAir	●



## COLOUR edition

<b>CAPACITY</b>	6 kg	
	7 kg	
	8 kg	●
	9 kg	
<b>ENERGY CLASS</b>	C	
	B	
	A+	
	A++	●
	A+++	
<b>DISPLAY</b>	LED diodes	
	LED	●
	LCD	
<b>OPERATION</b>	Vents	
	Condenser	
	Condenser with HeatPump	●
<b>CONTROL</b>	Sensors	●
<b>NO. OF PROGRAMS</b>	15	●
	27	
<b>DRUM CAPACITY</b>	117 l	
	120 l	●
<b>DRYING MODES</b>	NormalCare	●
	GentleCare	
<b>DRUM</b>	Drum illumination	●
	IonTech	
	SteamTech	●
	TwinAir	●



**D 98F66 EUK** Superior Line  
Freestanding condenser tumble dryer



- Colour: White



**D 95F65 NUK** Essential Line  
Freestanding condenser tumble dryer



- Colour: White

<b>Efficiency</b>	<ul style="list-style-type: none"> <li>- Dryer load: Large drum volume - 9 kg</li> <li>- IonTech technology</li> <li>- TwinAir</li> <li>- Heat pump</li> <li>- Drum volume: 120 l</li> <li>- Drum illumination with LED light</li> <li>- Porthole diameter: 35 cm</li> <li>- Door opening angle: 180 °</li> <li>- Reversible drum action</li> </ul>	<ul style="list-style-type: none"> <li>- Dryer load: Large drum volume - 9 kg</li> <li>- IonTech technology</li> <li>- TwinAir</li> <li>- Heat pump</li> <li>- Drum volume: 120 l</li> <li>- Drum illumination with LED light</li> <li>- Porthole diameter: 35 cm / Door opening angle: 180 °</li> <li>- Reversible drum action</li> <li>- Direct discharge of condensate AutoDrain</li> </ul>
<b>Control</b>	<ul style="list-style-type: none"> <li>- Personal settings for all programmes</li> <li>- Type of display: LCD</li> <li>- Presetting time delay of start</li> </ul>	<ul style="list-style-type: none"> <li>- Personal settings for all programmes</li> <li>- Type of display: LED</li> <li>- Presetting time delay of start</li> </ul>
<b>Programmes</b>	<ul style="list-style-type: none"> <li>- 27 programmes</li> <li>- Programmes: Cotton, Synthetics, Delicates, Mix, Wool, XL programme</li> <li>- SteamTech</li> </ul>	<ul style="list-style-type: none"> <li>- 15 programmes</li> <li>- Programmes: Cotton, Synthetics, Delicates, Mix, Wool, XL programme</li> </ul>
<b>Functions</b>	<ul style="list-style-type: none"> <li>- Lower temperature of drying</li> <li>- Anticrease</li> </ul>	<ul style="list-style-type: none"> <li>- Refresh</li> <li>- Anticrease</li> </ul>
<b>Features</b>	<ul style="list-style-type: none"> <li>- Audio signal SoftSound</li> <li>- FiltrationSupreme</li> <li>- Drying phase indicator</li> <li>- Signal for "full water container"</li> <li>- Remaining time on display</li> <li>- Vacuum feet</li> </ul>	<ul style="list-style-type: none"> <li>- Audio signal SoftSound</li> <li>- FiltrationSupreme</li> <li>- Drying phase indicator</li> <li>- Signal for "full water container"</li> <li>- Remaining time on display</li> <li>- Vacuum feet</li> </ul>
<b>SensorIQ technology</b>	<ul style="list-style-type: none"> <li>- Humidity sensor</li> <li>- Service diagnostic indicator</li> </ul>	<ul style="list-style-type: none"> <li>- Humidity sensor</li> <li>- Service diagnostic indicator</li> </ul>
<b>Safety and durability</b>	<ul style="list-style-type: none"> <li>- Protective thermostat</li> <li>- Automatic switch off when door is open</li> <li>- Child protection (CDP)</li> <li>- Stainless steel inner/outer drum</li> </ul>	<ul style="list-style-type: none"> <li>- Protective thermostat</li> <li>- Automatic switch off when door is open</li> <li>- Child protection (CDP)</li> <li>- Stainless steel inner/outer drum</li> </ul>
<b>Technical data</b>	<ul style="list-style-type: none"> <li>- Noise level: 66 dB(A)re 1 pW</li> <li>- Product dimensions (HxWxD): 85 × 60 × 60 cm</li> <li>- EAN code: 3838942079207</li> <li>- Product code: 517213</li> </ul>	<ul style="list-style-type: none"> <li>- Noise level: 65 dB(A)re 1 pW</li> <li>- Product dimensions (HxWxD): 85 × 60 × 60 cm</li> <li>- EAN code: 3838942079214</li> <li>- Product code: 517214</li> </ul>

2  
YEAR  
WARRANTY

**D 8565 N** Essential Line  
Freestanding condenser tumble dryer

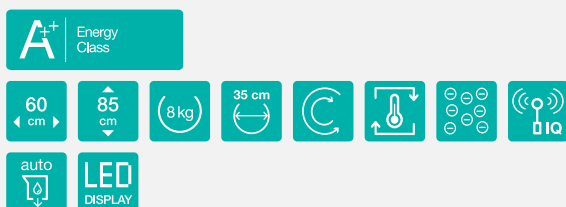

- Colour: White

2  
YEAR  
WARRANTY

**D 744 BJ** Essential Line  
Freestanding condenser tumble dryer



- Colour: White

<b>Efficiency</b>	<ul style="list-style-type: none"> <li>- Dryer load: 1-8 kg</li> <li>- IonTech technology</li> <li>- TwinAir</li> <li>- Heat pump</li> <li>- Drum volume: 120 l</li> <li>- Drum illumination with LED light</li> <li>- Porthole diameter: 35 cm</li> <li>- Door opening angle: 180 °</li> <li>- Reversible drum action</li> <li>- Direct discharge of condensate AutoDrain</li> </ul>	<ul style="list-style-type: none"> <li>- Dryer load: 1-7 kg</li> <li>- Energy-saving electric heater</li> <li>- Drum volume: 117 l</li> <li>- Drum illumination with LED light</li> <li>- Porthole diameter: 35 cm</li> <li>- Door opening angle: 180 °</li> <li>- Reversible drum action</li> </ul>
<b>Control</b>	<ul style="list-style-type: none"> <li>- Personal settings for all programmes</li> <li>- Type of display: LED</li> </ul>	<ul style="list-style-type: none"> <li>- Personal settings for all programmes</li> <li>- Type of display: LED</li> </ul>
<b>Programmes</b>	<ul style="list-style-type: none"> <li>- 15 programmes</li> <li>- Programmes: Cotton, Synthetics, Delicates, Mix, Wool, XL programme</li> </ul>	<ul style="list-style-type: none"> <li>- 15 programmes</li> <li>- Programmes: Cotton, Synthetics, Delicates, Mix, Wool, XL programme</li> </ul>
<b>Functions</b>	<ul style="list-style-type: none"> <li>- Refresh</li> <li>- Anticrease</li> </ul>	<ul style="list-style-type: none"> <li>- Lower temperature of drying</li> <li>- Anticrease</li> </ul>
<b>Features</b>	<ul style="list-style-type: none"> <li>- Audio signal SoftSound</li> <li>- FiltrationSupreme</li> <li>- Drying phase indicator</li> <li>- Signal for "full water container"</li> <li>- Remaining time on display</li> <li>- Vacuum feet</li> </ul>	<ul style="list-style-type: none"> <li>- Audio signal SoftSound</li> <li>- FiltrationSupreme</li> <li>- Drying phase indicator</li> <li>- Signal for "full water container"</li> <li>- Remaining time on display</li> <li>- Vacuum feet</li> </ul>
<b>SensorIQ technology</b>	<ul style="list-style-type: none"> <li>- Humidity sensor</li> <li>- Service diagnostic indicator</li> </ul>	<ul style="list-style-type: none"> <li>- Humidity sensor</li> <li>- Service diagnostic indicator</li> </ul>
<b>Safety and durability</b>	<ul style="list-style-type: none"> <li>- Protective thermostat</li> <li>- Automatic switch off when door is open</li> <li>- Child protection (CDP)</li> <li>- Stainless steel inner/outer drum</li> </ul>	<ul style="list-style-type: none"> <li>- Protective thermostat</li> <li>- Automatic switch off when door is open</li> <li>- Child protection (CDP)</li> <li>- Stainless steel inner/outer drum</li> </ul>
<b>Technical data</b>	<ul style="list-style-type: none"> <li>- Noise level: 65 dB(A)re 1 pW</li> <li>- Energy consumption kWh/year: 218 kWh</li> <li>- Product dimensions (HxWxD): 85 × 60 × 60 cm</li> <li>- EAN code: 3838942859045</li> <li>- Product code: 406642</li> </ul>	<ul style="list-style-type: none"> <li>- Noise level: 65 dB(A)re 1 pW</li> <li>- Energy consumption kWh/year: 504 kWh</li> <li>- Product dimensions (HxWxD): 85 × 60 × 60 cm</li> <li>- EAN code: 3838942914676</li> <li>- Product code: 415087</li> </ul>



## D 8565 NO Colour Edition

Freestanding condenser tumble dryer



- Colour: Juicy Orange

<b>Efficiency</b>	<ul style="list-style-type: none"> <li>- Dryer load: 1-8 kg</li> <li>- IonTech technology</li> <li>- TwinAir</li> <li>- Heat pump</li> <li>- Drum volume: 120 l</li> <li>- Drum illumination with LED light</li> <li>- Porthole diameter: 35 cm</li> <li>- Door opening angle: 180 °</li> <li>- Reversible drum action</li> <li>- Direct discharge of condensate AutoDrain</li> </ul>
<b>Control</b>	<ul style="list-style-type: none"> <li>- Personal settings for all programmes</li> <li>- Type of display: LED</li> </ul>
<b>Programmes</b>	<ul style="list-style-type: none"> <li>- 15 programmes</li> <li>- Programmes: Cotton, Synthetics, Delicates, Mix, Wool, XL programme</li> </ul>
<b>Functions</b>	<ul style="list-style-type: none"> <li>- Anticrease</li> </ul>
<b>Features</b>	<ul style="list-style-type: none"> <li>- Audio signal SoftSound</li> <li>- FiltrationSupreme</li> <li>- Drying phase indicator</li> <li>- Signal for "full water container"</li> <li>- Remaining time on display</li> <li>- Vacuum feet</li> </ul>
<b>SensorIQ technology</b>	<ul style="list-style-type: none"> <li>- Humidity sensor</li> <li>- Service diagnostic indicator</li> </ul>
<b>Safety and durability</b>	<ul style="list-style-type: none"> <li>- Protective thermostat</li> <li>- Automatic switch off when door is open</li> <li>- Child protection (CDP)</li> <li>- Stainless steel inner/outer drum</li> </ul>
<b>Technical data</b>	<ul style="list-style-type: none"> <li>- Noise level: 65 dB(A)re 1 pW</li> <li>- Energy consumption kWh/year: 218 kWh</li> <li>- Product dimensions (HxWxD): 85 × 60 × 60 cm</li> <li>- EAN code: 3838942271885</li> <li>- Product code: 454600</li> </ul>



### D 8565 NB

- Colour: Black
- EAN code: 3838942273414
- Product code: 454596



### D 8565 NA

- Colour: Silver
- EAN code: 3838942272226
- Product code: 454599



### D 8565 NR

- Colour: Fiery Red
- EAN code: 3838942272578
- Product code: 454597









# THE MASTER OF SHINY DISHES

## Dishwashers

Cooking and dining are the fun part; then comes the washing-up. This chore, often wastes your time that could be much better spent, is particularly tedious when a large amount of dishes piles up, and even more so when the dirt on them is dried and stubborn. Gorenje dishwashers will make sure your dishes are spotlessly clean. Thoughtful interior layout allows rational stacking of your dirty dishes, and the technologies employed afford environmentally friendly and economical washing.



## Adjustable baskets

Room for all shapes and sizes

Upper and lower baskets are adjustable to accommodate dishes of all shapes and sizes. The plate rack in the lower basket can be folded to allow more space for larger items. The lower basket also holds a special cutlery basket. The height of the upper basket is adjustable and it is also suitable for washing of the delicate stemware.



## Stainless steel interior

Dishwasher interior is made of stainless steel, which makes maintenance easier and useful life longer.



## Self-cleaning filter

The automatic filter cleaning system washes out the food residues to prevent the filter from clogging, and thereby also any problems or errors.



## 3 in 1

Simply by activating the “3 in 1” function, your dishwasher will automatically detect which type of detergent you are using. If you are using a tablet, the dishwasher will adjust the washing cycle and omit using the rinse aid, making this function highly convenient. If you are using powder or gel detergent, the rinse aid is released to allow optimum dishwashing results and perfect shine.



## AquaStop

In case of water spillage, the AquaStop safety system will automatically shut off the water supply to the hose and the machine, and the pump will pump out the remaining water from the dishwasher tub into the drain hose. Thus, the dishwasher may be left to operate at night or while nobody is at home, without any fear from flooding.



## Economical use of water

Dishwashers use up to 40% less water than the conventional models. High end models only use 11 litres with the Eco programme.



## Top energy efficiency

With an A<sup>++</sup> rating this Gorenje GS 62215 WUK dishwasher has one of the most efficient energy ratings. This dishwasher is A<sup>++</sup> rated. It will cost only £36 per year to run in terms of electricity.

(Costs based on EU Energy Label energy and water consumption. This assumes 280 loads per year. Average electricity price of 13.86p/kWh. Running costs will vary depending on usage. Correct as of January 2016).





**GS 62215 WUK**  
Freestanding dishwasher

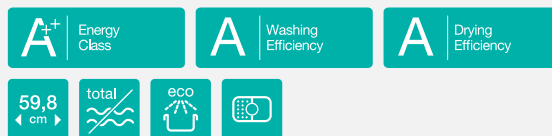

- Colour: White



**GS 62215 XSUK**  
Freestanding dishwasher

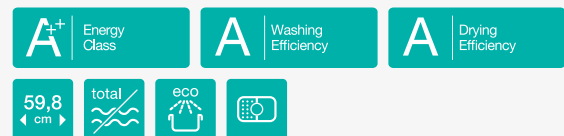

















- Colour: Silver

<b>Efficiency</b>	- Max. temperature of inflow water: 60 °C	- Max. temperature of inflow water: 60 °C
<b>Control</b>	- Selected programme indicator - On/Off indicator	- Selected programme indicator - On/Off indicator
<b>Programmes</b>	- Washing temperature(s): 40, 45, 55, 60 °C - 7 programmes: Normal; Half load; Sensitive programme; Intensive programme; Eco programme; Quick programme; Soaking - Reference programme: 4	- Washing temperature(s): 40, 45, 55, 60 °C - 7 programmes: Normal; Half load; Sensitive programme; Intensive programme; Eco programme; Quick programme; Soaking - Reference programme: 4
<b>Features</b>	- 12 place settings - Function 3 in 1 - Selected programme indicator - Visual indicator for wash finish on control panel - Voice signal for the end of washing cycle	- 12 place settings - Function 3 in 1 - Selected programme indicator - Visual indicator for wash finish on control panel - Voice signal for the end of washing cycle
<b>UseLogic technology</b>	- Start delay 2/4/6/8	- Start delay 2/4/6/8
<b>Equipment</b>	- Number of baskets: 2 - Variable top basket - Basket with handle - Foldable bottom plate baskets - Number of water jet levels: 4 - Number of sprinkle hands: 2 - Selfcleaning filter	- Number of baskets: 2 - Variable top basket - Basket with handle - Foldable bottom plate baskets - Number of water jet levels: 4 - Number of sprinkle hands: 2 - Selfcleaning filter
<b>Safety</b>	- Total AquaStop - Service diagnostics - Stainless steel tub	- Total AquaStop - Service diagnostics - Stainless steel tub
<b>Consumption data (IEC standard EN 50242)</b>	- Water consumption: 11 l - Energy consumption - normal program: 0.91 kWh - Estimated annual water consumption: 3080 l	- Water consumption: 11 l - Energy consumption - normal program: 0.91 kWh - Estimated annual water consumption: 3080 l
<b>Technical data</b>	- Level of noise (max.): 49 dB(A)re 1 pW - Product dimensions (HxWxD): 84.5 × 59.8 × 60 cm - EAN code: 3838942087714 - Product code: 523934	- Level of noise (max.): 49 dB(A)re 1 pW - Product dimensions (HxWxD): 84.5 × 59.8 × 60 cm - EAN code: 3838942088520 - Product code: 523935









# Symbol description









## COOKERS

	HomeMade oven
	GentleClose door hinge
	BigSpace, large oven capacity
	SuperSize baking area
	Telescopic oven guides - 1 level
	Triple glazed oven door with one heat deflector (CoolDoor)
	Double glazed oven door with one heat deflector (CompactDoor)
	Dynamic oven cooling plus DC+
	Dynamic oven cooling DC
	BoilControl prevents the food from boiling over
	ChildLock
	Wok gas burner
	Induction hob













	Upper & lower heater
	Upper heater
	Lower heater
	Circular heater and fan
	Large infra grill
	Small grill
	Large infra grill and fan
	Lower heater and fan
	Lower heater with circular heater and fan
	Defrosting
	FastPreheat
	AquaClean
	WarmPlate, for professional service
	Gas thermostat
	Gas infrared burner
	ECO baking





## COOLING APPLIANCES

	NoFrost Plus
	NoFrost
	FrostLess - Less ice building in the freezer
	AdaptTech cooling - Memorizing intelligent system
	IonAir with the MultiFlow 360° function
	IonAir with DynamiiCooling
	Fan-assisted cooling in fridge
	ZeroZone drawer
	FreshActive drawer







	ConvertActive fridge freezer
	SuperCool function for rapid cooling of a major quantity of food
	CrispZone with HumidityControl - big vegetable drawer with humidity regulation
	FreshZone drawer
	FastFreeze - rapid food freezing
	CrispActive drawer
	PullOut shelves
	SimpleSlide shelves
	LED light







## WASHING MACHINES

	Load 1-9 kg
	Load 1-8 kg
	Load 1-7 kg
	Load 1-6 kg
	SensorIQ system - advanced sensor technology
	Durable heater DuraHeat
	Total AquaStop, spill protection
	AquaStop, spill protection
	LED display
	LCD display
	FiberTech tub material
	CarboTech tub material



	SpaDrum, special drum construction
	StainExpert efficient stain removal
	TotalWeightControl
	Inverter PowerDrive efficient brushless motor
	Low temperature wash 20 °C
	SterilTub self-cleaning program
	StartDelay 24h in advance
	Spin speed 1600 rpm
	Spin speed 1400 rpm
	Spin speed 1200 rpm
	SuperSilent

## TUMBLE DRYERS

	Load 1-9 kg
	Load 1-8 kg
	Load 1-7 kg
	SensorIQ system - advanced sensor technology
	Condenser dryer with a heat pump
	IonTech anti-bacterial treatment

	TwinAir - Special two-directional air blowing system
	SteamTech steam drying technology
	AutoDrain - direct discharge of Condensate
	LED display
	LCD display
	Door opening 35 cm

## DISHWASHERS

	Total AquaStop, total spill protection
	ECO programme
	Function 3 in 1



## FREE 5- or 2- YEAR PARTS AND LABOUR GUARANTEE

Once you make your purchase you will need to register your appliance either online or over the phone, to register your Gorenje appliance online please visit our website [www.gorenje.co.uk](http://www.gorenje.co.uk) and go to “registration” OR to register over the phone please call **020 8247 3980**

Gorenje offer a free 5 or 2 year parts and labour guarantee. This guarantee shows our confidence in our technology and excellent product quality.

# AFTER SALES SUPPORT

Once you have bought a Gorenje appliance you can relax knowing that in unlikely event of a fault occurring, you can rely on us to look after your appliance. If you are experiencing problems and require customer support please contact our Service Hotline on:

**0844 557 9000**  
(Republic of Ireland: 01 8835622)

**Please have all your appliance details and date of purchase ready in order for your call to be dealt with efficiently.**

Service Hotline opening times:

- Monday - Friday 8am - 6pm
- Saturday 9am - 4pm
- Sunday 11am - 3pm

# **gorenje**

**GORENJE UK Ltd**  
Tuition House  
27-37 St George's Road  
London  
SW19 4EU  
T 020 8247 39 80  
F 020 8247 39 99  
E [info.uk@gorenje.com](mailto:info.uk@gorenje.com)  
[www.gorenje.co.uk](http://www.gorenje.co.uk)